



SHORT LINE

Sierra Division * Pacific Coast Region * National Model Railroad Association



The
**World's
Greatest
Hobby!**

Inside This Issue

October Picnic	2
Building Contest (see From the Editor)	3
Great Web Sites	8
PCR Registration 2012	9
Bolster Design	10
August Meet Photos	10
Flat Car into Gondola	11
Anatomy of a Flat Car	13
Flat Car Plans All Scales	16
Carson & Colorado Flat	22
SP CS-30 Flat Car	29
Thanks to Contributors	33

Scratchbuilding Wooden Freight Cars 101: A Generic Truss Rod Flat Car

by Martin Brechbeil (Model Photos by Barb Keller)

Original article from THE LOCAL/MID-EASTERN REGION/NMRA
March/April 2004 Reprinted with permission
Instructions for 0 Scale but can be modified for any scale

You are reading along in your favorite railroading magazine and run across a picture of an old-time wooden car that really catches your eye. You decide that you just have to have one because it will look ideal sitting on that empty siding or behind that mixed freight. Now that you've decided on the goal, where do you get one?

The first and easiest solution is your

of those merit awards in car building and structures.

If plans were not in the article you were reading, with a little research, you can usually track down adequate ones. A few good pictures, an article or two, maybe a photocopied page from a borrowed book, and you can be on your way to the workbench! Still, you really need a starting point and here's where we get



into a brief discussion about tools and materials. Since I started out talking about a wooden car, we're going to be building a wooden car in this article.

local hobby shop, except you find after arrival that: (a) they don't have one; (b) there is no kit in production or never has been; or (c) there's a brass model that your loan officer will never approve. What are your options? You can hunt for an elusive and scarce kit if there is one, break down and take out a loan, or give up and move on. Or you can scratch build it yourself! This is not as hard as it might seem. Scratch building can really be a lot of fun, fuel your creativity, and provide a means to start achieving some

Despite some arguments to the contrary, I advocate building in wood since wood really looks like, well, wood, stains like wood, and paints like wood. There are several suppliers of scale lumber (basswood and others) and various types of specialty scribed sheet lumber: Northeastern, Kappler, Mt. Albert, and others. I frequently cut my own scale lumber.

Working in wood requires a good fine razor saw, miter box, a small square, sandpaper, and a few very sharp modeling knives. Don't forget a good scale

FLAT CAR | Page 4

Follow this link for the expanded digital color issue of the Short Line:
<http://www.pcrnmra.org/sierra/index.html>

Sierra Division Callboard

PCR business or questions:

Director

Mary Moore-Campagna
marycmoore@campagna.com
(415) 672-4806

Sierra Division business, questions, or
to volunteer to give a clinic, for mem-
bership problems,

SHORT LINE

subscription or address problems:

Superintendent

Jim Long
jimclong@sbcglobal.net
(530) 676-1798

To volunteer your layout for a tour or
"Timetable" entries:

Chief Clerk

Bob Warner

bkwarner51@comcast.net
(916) 772-7502

Paymaster

Al Rowe
HOFUNAR@aol.com

For article or photo submissions:

SHORT LINE Editor

Gary Ray
gerber1926@gmail.com
(530) 873-0626

Contest Chairperson

Vacant

For Golden Spike or NMRA

Certificate questions:

Achievement Program

Dave Bayless
(530) 887-8880

Webmaster

Gus Campagna
gus@campagna.com
(707) 664-8466

SHORT LINE is published quarterly by the Sierra Division of the Pacific Coast Region of the National Association. Material may be reprinted with permission.

Articles, photos, tips, or ideas are heartily encouraged and will be enthusiastically accepted! The preferred format would be in Rich Text Format (RTF), with photos as JPEGs, but we will accept any format (from a PC or Mac; MS Word, Simple Text, typed, or handwritten). Send it to your editor by regular mail to **SHORT LINE**, 6601 Ray Family Lane, Magalia, CA 95954 or by email to gerber1926@gmail.com.

If e-mailing put EDITOR in the subject line.

From the Superintendent

The **Sierra Division** will have a picnic on **October 8, 2011** at the Nevada County Fairgrounds. This is located at 11228 McCourtney Road, Grass Valley 95945. We will start about **10:30AM** with a tour of the **Nevada County Narrow Gauge Model Rail-**



road located on the grounds. This group is our host for this event. They have a fairly complete model of the entire Nevada County Narrow Gauge Railway from Colfax to Nevada City and they have been building it for many years and it looks good. We will be serving lunch about noon. We are planning hamburgers, potato salad, drinks. After lunch and our meeting we will visit the **Nevada County Narrow Gauge Railroad Museum** in Nevada City. We will need to know how much food to get so please **RSVP to Jim Long at 530-676-1798 or jim-clong@sbcglobal.net** The Division will buy

the food. The museum and model railroad ask for donations so please help if you can. I hope you remember the last Short Line and the feature article about NCNGRR. We were going to have our picnic there in August but it was the same weekend as the County Fair. You can still see the last Short Line on the Sierra Division web site at <http://www.pcrnmra.org/sierra/>

At our business meeting on October 8 we will have nominations for the Sierra Division's Director to the PCR Board of Directors. Mary is our current director and she can't run for another term, so we need someone to replace her. The election will be held by PCR next winter and the new Director will take over at the PCR Convention in May.

International Railfair is coming up on **November 12 and 13**. This is the **Sierra Divisions only fund raiser and your help is needed more than ever**. We have work shifts available on Saturday and Sunday. We have to staff the ticket booth, Sierra Division Information Booth with the Time Saver and Thomas' wooden RR for the little kids that is located on the stage. There is also setup on Friday. We can also use some help on Sunday afternoon with clean up and putting things away. **Please contact me if you can help.**

November 25 and 26 is the Small Train Weekend at the California State Railroad Museum. The Sierra Division is setting up an NMRA information booth with the Time Saver for the kids to operate. We need volunteers to staff the booth. I am thinking of 2 to 3 hour shifts. If you help we can get you a pass to the museum so you can see it during your visit. **Please contact me if you can help.**

We have several items to discuss at our business meeting. We have a proposal for a contest about building Laser Cut Kits. Gary Ray is asking people to build a flat car. There are some interesting proposals, Nominations and other important issues.

As always we have some jobs that need to be done. I would like to see a layout tour weekend in the Sacramento area but we need someone to organize this. I have one more year as Superintendent but will have to step down at that time. My health is becoming more restricting as time goes on. We will need someone to run for election at the end of next year.

There will be the **Layout Tours in Northern Nevada on November 4, 5 and 6**. Please see the web site <http://www.highsierramodelrrtour.com/> for more information. The layouts that will be open along with dates and times will be posted a week or so before the weekend. I would like to thank **Jim Petro** for setting this up. He says there

are at least eleven layouts on the tour including a new On30 and he expecting a few more.

Jim Long

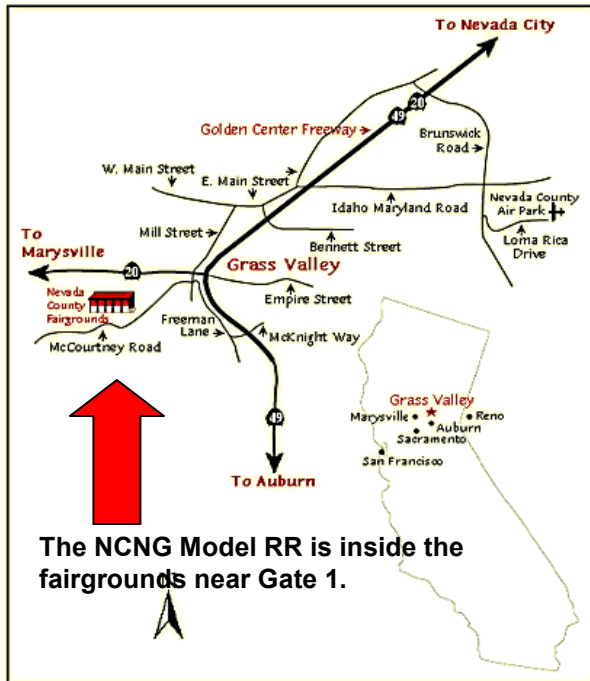

Nevin Wilson's layout (above) and Jim Petro's are just two of the dozen or so layouts on Northern Nevada tour.



IDEAS WANTED ~ Editor wishes to add "HOW TO" more modeling content to newsletter. If you have an idea or know of a website with a great idea, PASS IT ALONG IMMEDIATELY or your stuck with my ideas! I'd like the newsletter to be useful to you and promote more participation. I hope I'm reaching my goal. gerber1926@gmail.com

From the Editor

One of the problems of being the editor is content. As mentioned last issue, I was looking for more "HOW TO" articles. Since none were forth-coming and we don't have a Contest Chairperson, I decided to challenge the members with a "Modeler's Challenge." I recalled the "Sunrise Mill" kitbash challenge in October of 2009 that gave members a chance to create some really nice models. Hopefully members learn from the process and from each other.

So, the October 2011 challenge is to scratch build a flat car and bring it to our February 2012 meeting. You choose the construction material. Flat cars from early 1900's are easy to construct and give lots of opportunity to weather or build a load on. Modern modelers; this museum piece could be a load on it's way to a museum or to a facility to restore it, or perhaps it has already reached it's display destination.

This month's **Digital Short Line** has over 20 pages of articles and plans for Z to O scale. All show wood, but styrene could be used. I get bass wood from the local hardware

store and cut it to size. One plan is simpler to build in that there are no stake pockets. (If you can't download the digital version at home, try a friend's house, public library, or for years I used a hot spot and a laptop in town.)

Jim assures me that there will be prizes for all scratch-built models shared at the February meeting. Perhaps even an informal judging.

A friend of mine, **Klaus Keil**, asked if he could share **flatcar loads** in February. This is a great idea. So **even if you don't build, share something.** I continue to search for ways to share information that you can use on your layout. I will photograph all models for the April edition of **Short Line**.

I know our division is large and spread out. I have to drive 100 miles to Sacramento for a meet. Consider car-pooling with others. **If you can't make the meet and have constructed a car or have a flatcar load you would like to share, please send me a jpeg along with a description.** In this way, more people can be involved.

FLAT CAR FROM PAGE 1

ruler and a fine marker; I like a 0.5 mm mechanical pencil. There's an endless assortment of other tools like a pin vise and a set of drills, tweezers, files, gluing weights, clamps, clothespins, etc., and you'll accumulate the tools that work best for you. Assembly requires glue, and more than one type is generally needed to handle all types of materials that you'll be joining to wood. First, a good carpenter's glue is useful, but warping from too much moisture in this type of glue limits its use. Second, CA adhesives tend to be used the most, and I find that a generic brand medium viscosity works just fine 95% of the time. The one time that neither of these works well is in gluing the end grain of wood to nearly anything else, but particularly when making a butt joint. This forms a notoriously weak joint with just carpenter's glue and CA tends to just be soaked up by end grain. This brings us to the third glue in the adhesive arsenal, the old standby, Walther's Goo, or its equivalent. Good, thick, flexible contact cement that does not let go, allows time for positioning, and can then be locked or set with CA is just very handy. Also, there are several mixed materials joints for which this type of glue is suitable; metal to wood is just one example. I have several different work surfaces as well. They range from a 2 by 4 foot sheet of fine surface oriented strand board, an 18-inch-square piece of 1/4" plate glass, a 2 by 4 foot acoustic ceiling tile, and a one-foot-square piece of marble tile. A roll of wax paper comes in handy as well.

Lastly we arrive at finishing, i.e., staining and painting. I advocate staining the wood you plan to build with as far in advance as possible for each project. Any glue that may leak out from whatever joint onto an exposed surface will later impact staining or painting and may even block it totally. There are a host of stains and articles detailing their use. In general, I use a variety of MinWax stains and several different thinned colors of Floquil and Polly S. I follow them with airbrushed oversprays of Grime, Rust, Grimy Black, and Roof Brown and finish up with powdered chalks. Experiment with all of this until you find what you like for your projects. Again, it's fun, pushes your creativity, and you never know what kind of interesting results you might create. We need a good, simple starting point project. Since nearly every car is a variant of, or starts out as a flat car, this will be our entry point for scratch building wooden cars. Once you have this mastered, all you need to build a gondola is an open box on your flat car. A boxcar is a closed box on a flat car; a reefer is a special boxcar, and so on. You can extend this to nearly any type of train car you might want to build. With all that out of the way, let's get building!

Step 1

Construction begins with building a box which serves as the perimeter frame of the flat car. You need to find the two 6" x 12" x 8 1/2" end sills and the two 6" x 12" x 38" side sills for building a box (Fig 1).

Make sure that these paired pieces are exactly the same in length, and if not, sand them to match! Also, make sure that the interior beams also match the length of the side sills. And, one

part of this is to not worry about the length being exactly 38"; your car can be shorter, longer, narrower, whatever you would like it to be, except longer. One of the fundamental objectives of this kit is to be able take a pile of sticks and come up with a credible, generic truss-rod flatcar.

If you feel creative, you could assemble these parts using simple or complicated lap joints, but that is not always practical

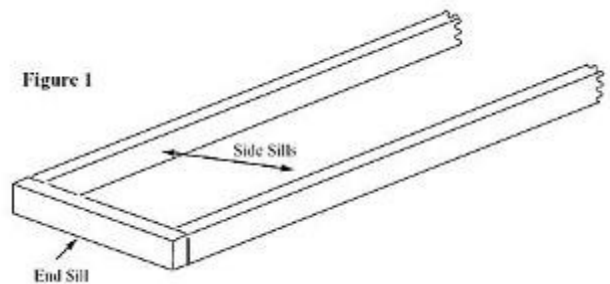

so we'll make do with a butt joint. The use of Walther's Goo is recommended for this step since wood glues and ACC are notoriously weak for this kind of joint. A small dab on the ends of the side sills will serve to assemble the frame and allow you to adjust it at your leisure to get square. I trust my eyes, but you can verify square using a small machinist or carpenter's square or by measuring the diagonals; these should be equal in length. This Goo step is to just set up the frame for the next step – putting on the decking. Don't worry about putting the other 4 beams in just yet; these go in much easier after the decking is in place!

Step 2

Scribed sheet is really too neat and tidy looking. And, unless you use two sheets back-to-back you don't get the visual effect of boards from the underside, for those that do look under their cars. We'll use individual boards and not those nice and smooth scale boards, but something that provides random widths and having a rough, worn surface that ages the appearance to add some surface character. These tend to come in random widths (5-8") and a useable thickness (~2 1/2") for this car in 'O' scale. One thing you have to be careful about is that these are not basswood; they are a hardwood, probably birch, so cutting these can be a little tricky. I use a band saw and a heavy utility knife as needed, and sometimes use a 4" belt sander for finishing.

There are ~60 deck boards supplied natural or pre-stained to deck this car. These are cut close to, but a bit longer than the needed width. You can trim the excess later, or if you are very careful, align these for an overhang. One caution about wood, you can trim it later, but it's hard to lengthen it if you've cut it too short early on. Now, pick out 4-6 "nice", straight deck boards and after laying down a bead of CA on the top of the end sill and about the distance of what would be ~3 deck boards down the side sills, and glue down ~3 deck boards (Fig. 2). Do this at each end and be careful not to disturb your nice square frame! Press these boards down firmly and try to not glue yourself to the car. Repeat from the other end of the car frame. With

these two operations completed your car frame is set and you can insert the interior stringers.

Step 3

Flip over this assembly and now you can drop in your four 4" x 12" x 38" stringers (Fig. 3). These can be spaced equidistant or not, but should be symmetric. Depending of the car and type of truck bolster, their placement can vary both in spacing and in size. Make sure they fit with minimal friction; you don't want to bow these into place. Sand and test fit until they fit, but again, don't sand too enthusiastically, reversing the process does not

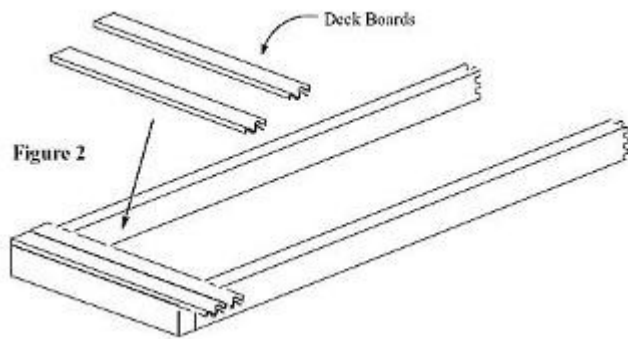

work very well.

A dab of Goo on the end and a bead of CA on the surface of the stringers towards the underside of the decking that you did at each end locks each stringer into place. Now flip your assembly

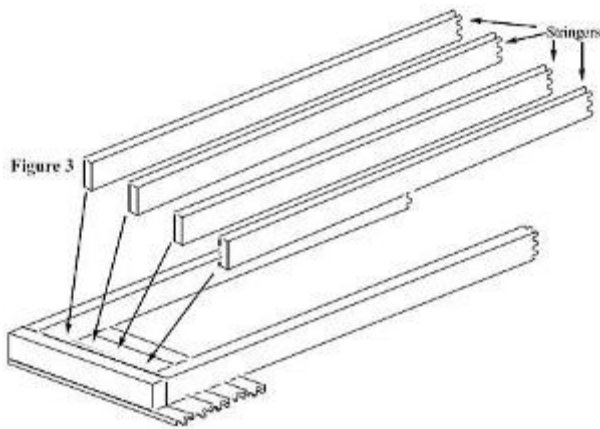

back over, run beads of CA down the tops of the side sills and the interior stringers and glue down your deck boards. Try to pick "interesting" boards, color, grain, "knots", but also stay with the straighter ones and try to avoid any that are not unless you can match up complementary boards.

As you get close to meeting the two ends of deck boards that you are laying from each end, start planning those boards that you want to use to finish the remaining open section in advance. You do not want to end up with an awkward gap, but rather with a space close in width to a board you have picked out that can be "massaged" or sanded into place. After this step is completed and the glue is set, you can trim the deck boards flush with the side sills or trim them to suit your personal design.

Step 4

Let's get into some of the underbody parts and details. Flip the assembly over again. **Optional: If you want to put a train line in, now is the time. Form this from 0.28 wire with an "S" curve and place into some notches cut with a sharp knife into the center 2 stringers (Fig. 4). If desired, addition of a glad hand to the end this wire dresses up the end of the car nicely. A dab of Goo in those notches holds this wire in place.** To really anchor this, you need to put in the body bolsters where the trucks will be mounted. There are a host of commercial choices in brass, plastic, and even wood, and what is supplied here are resin castings that you can drill and tap for 4/40 screws to mount trucks. However, if you manage to locate

some old white metal or bronze castings the added weight is a great addition.

The bolsters straddle the entire underbody resting on the side sills and all of the support beams in between. Secure these with

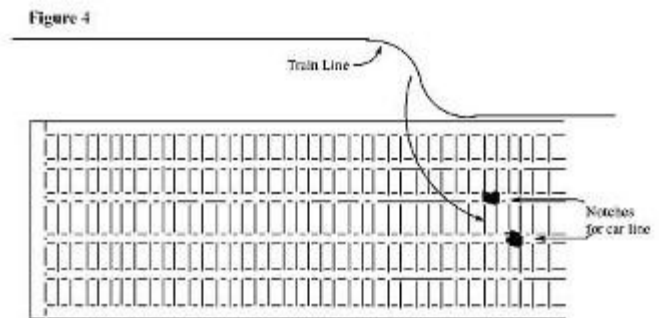

some CA on all 6 contact points centered 6 1/2" in from end of the car (Fig. 5).

While on this side of the car you can address placement of the remaining structural parts, some details, and the brake system. The 2 cross-member needlebeams (6" x 6" x 8 1/2") that the queen posts will be mounted on can be set into place. Glue these down with CA 14 feet in from the end of the car (Fig. 5).

A more modern car would have a set of AB brake system castings. But, being an older truss rod car, there's just a single K brake casting here. The K brake casting goes roughly where it is located in Figure 6. Take some of your leftover decking boards and fashion a mounting platform 3-4 boards wide for the K brake casting (Fig. 6) straddling 2 of the stringers and secure them with CA.

Think ahead at this point about where the truss rods and turnbuckles need to run through this maze you're creating so that you leave four pathways. After the glue is dry, if you like, you

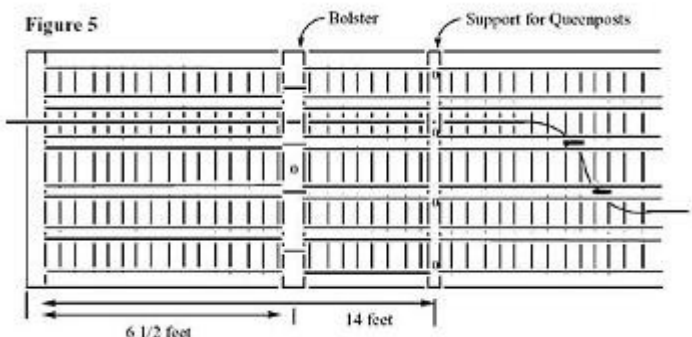



these in, let's address those pesky truss rods and the turnbuckles.

There are two (and probably a lot more...) options that can be used. In this version of this kit, these are made out of thread; #0 surgical silk, in fact that is installed in one piece of thread that is trimmed later. Here's how to do that: 1st, thread one end from the inside of the un-

derbody out through one of the end sill holes that you drilled. Secure that end of the thread with one of those nbw's for the end by inserting it into the same hole with a little ACC from the outside anchoring the end of the thread. Thread a turnbuckle casting onto the silk and "tightly" thread the other end of the silk through the corresponding opposite end hole and again anchor the silk with an nbw inserted from the outside with a little ACC. Leave the silk off of the queen posts until the ACC has secured the ends. You can lift it up onto the corresponding set of queen posts after all 4 truss rods are installed making sure that you place the turnbuckles in the center between the queenposts. These can be secured with a dab of ACC. Having the 1st installed, you merely need to continue threading the silk through the holes from end to end, remembering to add a turnbuckle at each passage, securing at each hole with an nbw and some ACC. You should have just enough thread to do this operation.

The other option here is to replace the thread with brass wire from Detail Assoc. and use brass turnbuckles, etc.

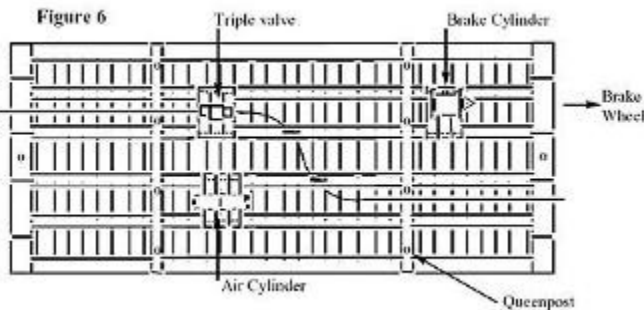

Step 5
Since you've been thinking about where you are going to put those truss rods, let's get those installed now. Drill holes in the needle beam cross member to mount the queen posts (Fig. 6). The 5" queen posts are Grandt Line #68 and the "bolt" off the sprue can be accommodated by a #67 drill bit. Drill 4 holes with a pin vise (or a hand drill or drill press) in each cross member, carefully cut each queen post from the sprue at an angle using a sharp knife or sprue cutter. A bit of CA on the bolt and application of gentle pressure with that angle cut and each queen post will drop right in. Make sure you have these aligned correctly so that the truss rod running from end to end will rest correctly on the queen post. Now that these are mounted, you can drill holes in the ends of the end sills for the nbw's that are to represent the ends of the truss rods. These are again from Grandt Line (#16 or #81) and there are several styles to choose from and usually require a #58 drill. I like to use the ones with a nice big round or square washer that shows nicely after painting. You can drill these holes with a pin vise again, or as I do, with a hand drill. You need 4 in each end to correspond with the 4 pairs of queen posts and these should be aligned in a straight line. **But, before you put**

Step 6
Now, you're almost finished. Just add the stirrup steps and the brake wheel with ratchet & pawl assembly. The #83 Grandt Line stirrup steps at each corner are applied by first drilling #72 holes that correspond with the bolts on these castings followed by glue with a drop of CA on each bolt with a discrete amount on the surface towards the car side sill (Fig. 7). The brake wheel casting assembly, Grandt Line #33, tends to be very delicate. Carefully ream out the center of the brake wheel with a #72 drill and glue to a short length of 0.025 phosphor brass wire (trim to a reasonable length...) so that the end is nearly flush with the top of the wheel. Similarly, ream out the hole in the

Figure 7

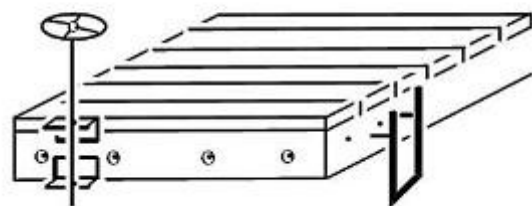

ratchet & pawl gear. Very, very carefully, with a sharp knife, free the wheel from the casting sprue. Similarly free the ratchet & pawl casting and thread this on the brake shaft and set this aside. To simplify mounting the brake wheel, just drill a #72 hole in the deck close to the end as in Figure 7, and secure with a drop of CA. Secure all with either CA or Goo with the brake wheel at a reasonable height.

Final options include grab irons (make your own from brass wire or use some from Precision Scale) and stake pockets (included!) to dress up that otherwise naked car side. To add weight, build a load for your flat car! Arch bar trucks would be appropriate and the plastic Athearn trucks are fine, but you can replace the wheel sets with metal wheels for smoother rolling and a lowered center of gravity weight. Mount these with a small wood screw. Finally, to add some Kadee couplers you'll have to add a block from the scrap box between the 2 center stringers to mount the coupler box. I like to use 3/8" #0 wood screws for this. Check for height and you'll either add a washer or sand the bolster. Some paint, stains, weathering, and lettering if desired and you'll have a pretty good truss rod flat car that gets you started in scratch building in wood!



An A-frame side dump gondola can be built or add some "stuff" for a black smith car or even more stuff for a crane and tender car.



A flat car can be turned into a gondola. An article begins on page 11 of the [Digital Short Line](#). (below) Mount a tank.



SIERRA DIVISION

Next Meeting: Saturday, October 8

Place: Nevada County Fairgrounds

11228 McCourtney Road

Nevada City, CA

Time: 10:30 AM

TIMETABLE

October 8

Feb. TBA

SHORT LINE

DEADLINES

Jan. 7 for the Feb. issue

Great Web Sites

Yahoo Groups offers lots of groups that have files, discussions, and pictures to aid in scratch building. Joining a group is a simple process.

Usually you have to wait a day or so for approval. Go to:

<http://groups.yahoo.com/> Search "scratch building" for a list.

Some places to start:

2684 members: <http://groups.yahoo.com/group/buildingsandstructures/>

5126 members: <http://groups.yahoo.com/group/casting/>

970 members: http://groups.yahoo.com/group/Model_RR_Structures/

1300 members: <http://groups.yahoo.com/group/Scratch-building/>

Another site with ideas for casting railroad cars, making Homasote road-bed, spray booth is Craig Bisgeier's site : <http://www.houatonicrr.com/>



Editor's correction: Last issue I gave credit to Paul Volker for **Southern Co-
perage Mills** on page 8. Credit for this beautiful should go to **Bob Wirthlin**.

SIERRA DIVISION AREA

HOBBY SHOWS & RAIL-FANNING EVENTS

FOR MORE EVENTS OR INFO, GO TO WWW.PCRNMRA.ORG/PCR/CALENDAR/MASTERCALNDAR.HTM

Nov. 4 to 6



Presented by PCR Sierra Division

[Chuck Gardner Northern Nevada Model Railroad Tour](#)

Visit home model railroad layouts in a wide variety of gauges.

Info: Jim Petro jeptro@sbcglobal.net

Website: www.highsierramodelrrtour.com

Nov. 12 & 13



[35th Annual International Railfair](#)

Saturday: 10 am to 5 pm, Sunday: 10 am to 4 pm

Placer County Fairgrounds

800 All American City Blvd., Roseville, CA

Co-sponsored Presented by
PCR Sierra Division

Website: www.internationalrailfair.com



**PNR/PCR/NMRA
SISKIYOU SUMMIT 2012
Joint Convention
Red Lion Hotel, Medford, OR
May 2-5, 2012**

RETURN FORM AND PAYMENT TO:
SISKIYOU SUMMIT 2012
c/o James Long
3716 Toronto Rd.
Cameron Park, CA 95682
E-mail: SiskyouSummitReg@pcrnmra.org
Website: <http://pcrnmra.org/conv2012/>

Hosted by: Pacific Northwest and Pacific Coast Regions, National Model Railroad Association

Registration Form

Credit card order not yet available, will be soon.

Last Name		First Name		First Name (For Badge)		MMR#	
Address		City		State or Province		Zip or Postal Code	
Country		Additional Address Information					
Home Phone		E-mail Address			NMRA # (Membership Required)		
Registration Type (Please check one) <input type="checkbox"/> Model Railroader <input type="checkbox"/> Sidetrack <input type="checkbox"/> Youth				NMRA Region			
Primary Scales and Interests (Check all that apply) <input type="checkbox"/> HO <input type="checkbox"/> S <input type="checkbox"/> N <input type="checkbox"/> O <input type="checkbox"/> G <input type="checkbox"/> Narrow Gauge <input type="checkbox"/> LDSIG <input type="checkbox"/> OPSIG <input type="checkbox"/> Other:							
ADDITIONAL REGISTRANT LIVING AT SAME ADDRESS (Use another form for more than 1)							
Last Name		First Name		First Name (for Badge)		MMR#	
Registration Type (Please check one) <input type="checkbox"/> Model Railroader <input type="checkbox"/> Sidetrack <input type="checkbox"/> Youth				E-Mail (If Different)		NMRA #	
All Fares are in US dollars, includes Clinics, Layout Tours, other items may be added later.							
FARES: Please fill in QTY and Total				QTY	Unit Cost	Total	
Full Fare Registration					55.00		
Early Bird Registration – Before November 1, 2011					45.00		
Sidetrack Registration					25.00		
Sidetrack Registration – Before November 1, 2011					20.00		
Youth Registration (under 18 years or student)					10.00		
Day Fare <input type="checkbox"/> Wed <input type="checkbox"/> Thurs <input type="checkbox"/> Fri <input type="checkbox"/> Sat					25.00		
Non NMRA member must join the NMRA (For new US Members only. New members from other countries, contact local Region)				6 month Rail Pass (allowed one time only)			9.95
				Full NMRA membership/PCR or PNR subscription			64.00
Banquet (Choice of Entrée will be provided later)					35.00		
Payment by <input type="checkbox"/> Check** <input type="checkbox"/> Cash						TOTAL:	
** Make Checks Payable to: "Siskiyou Summit 2012" No Refunds After April 1, 2012							

Hotel information can be found on website: <http://pcrnmra.org/conv2012/>

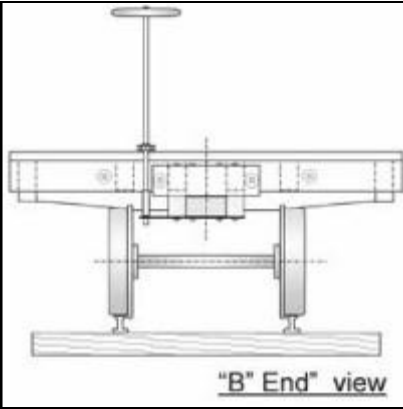

Excerpts from **Chris Butler's** scratch-building article are included below for those unable to receive the [Digital Short Line](#) where the article is reproduced in full. Here is an idea for a bolster for the flat car.

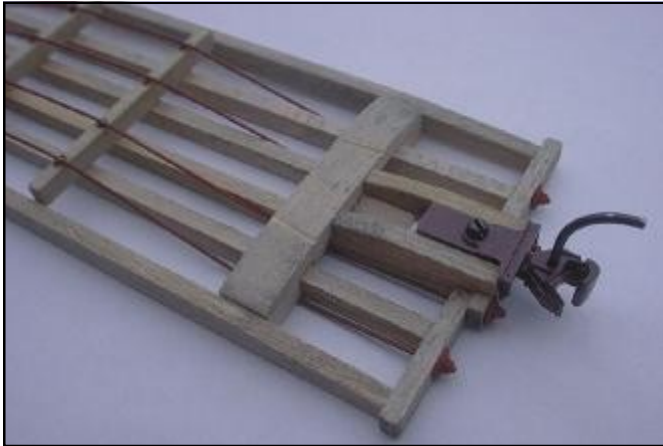
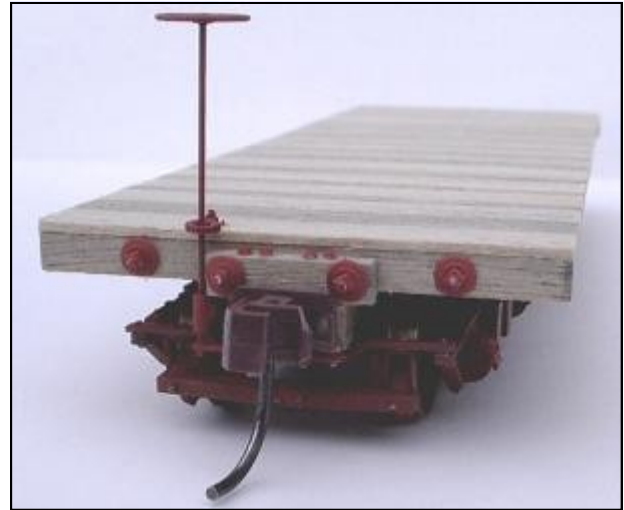

Chris Butler's entire article on constructing a Carson & Colorado 22' Flat Car can be found at:

<http://www.cabutler.com/rr/on3/index.html>

Published with permission



Jim Long took these photos at the August 13 Meet held in Carson City. Attendees were treated to a scenic ride behind engine #18.

#18 is a 2-8-2 built by Baldwin in 1914 and acquired new by the McCloud River Railroad. Later it was used on excursions by the Yreka Western and now resides on the Virginia and Truckee.

[Click to see more photos | Page 33](#)

Scratchbuilding Wooden Freight Cars

—Convert Your Flatcar into a Gondola—

By **Martin Brechbiel**

Photographs by Barbara Keller

(Published with permission from *The Local—A Publication of the Mid-Eastern Region of the NMRA, Sept./Oct. 2004*)

SO, by now I'm hoping that you've scratch built a flatcar, something along the lines as described in the March-April, 2004 issue of **The Local** and dressed it up with grab irons, trucks, and some sort of creative load. But flatcars are just that—flat—and have limited appeal and utility. Fortunately, flatcars are also a good, simple starting point to build other cars and provide a base for a host of other cars to scratch build. I know I said a boxcar was next, but that skips over the intermediate car in the development chain, a gondola, which is just an open box on your flatcar put there so your load doesn't fall off. This is probably the quickest and easiest extension from the basic flatcar, so let's get building!

Construction begins, of course, with another flatcar, but interrupt that process before adding the brake wheel, stirrup steps, and any other details; add them later so they don't get damaged. I'm working with a 38-foot car in O-scale, but you can modify dimensions to suit both choice of scale and length and width of your car. The part numbers

mentioned are also the O-scale numbers. Let's build the box sides and ends first. I used eight Kappler HO-scale 4x22s cut to 32 feet for the sides. Lay these side-by-side, square, and marked every four feet. Then glue a scale 4x4 across all eight boards every four feet

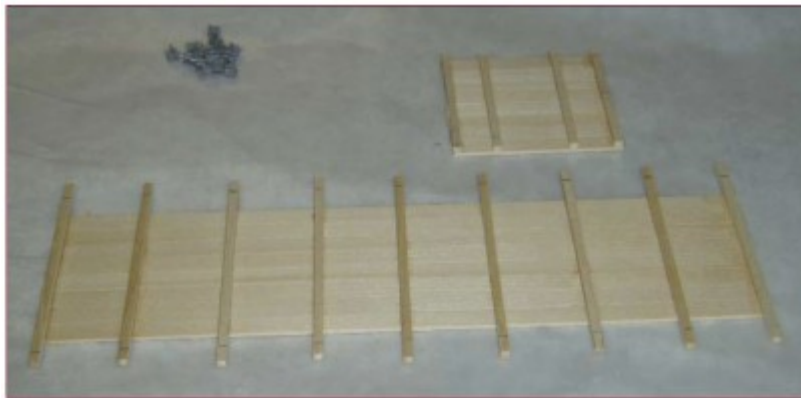

Figure 1



Figure 2

and at the ends (Figure 1). You want these 4x4s to overhang by at least the width of the side sill of your flatcar. Do the same exercise with eight more boards that are as long as the width of your flatcar minus twice the thickness of your side boards. Glue a scale 4x4 across all eight boards two feet in from each end and at the ends (Figure 1). These 4x4s should be flush with the ends. Now, with your razor saw, cut the 4x4s on each assembly right in the middle so you have the two sides and the two ends for your gondola's box (Figure 2). Rather than place stake pockets on the flatcar and hope to get everything aligns so you can thread the stakes in, just mount the stake pockets directly to the stakes.

Square off those overhanging 4x4 stakes to the side sill width and glue on stake pockets (Grandt Line No. 53). Cut the mounting sprues off the stake pocket castings and after gluing them onto the stakes (try to put them on oriented the same way), make sure that the reverse is a nice smooth surface. By putting a drop of glue on the back of each stake, you can mount the gondola sides to the

side sill centered to the car. The two ends should now drop in between the two sides. A little sanding may be necessary. A little glue on those two end stakes and your gondola box is both assembled and mounted. The completed assembly is shown in Figure 3.

Next, you can run a truss-rod or two through both ends (.022 or .018 diameter wire) with turnbuckles (Grandt Line No. 54 or equivalent). Place nut-bolt-washer castings (Grandt Line No. 23) at every intersection all around the box as well. Lastly, you can add your brake wheel, ratchet and pawl, stirrup

steps, grab irons, uncoupling levers, trucks and couplers, and what other details you'd like to finish your gondola. Now put together that load of pipe, sugar beets or turnips, or whatever you'd like to carry from point A to point B. One variation is to leave the ends off and use your car with idler flatcars on each side to carry really long items. A more sophisticated variation of our gondola would be to add drop-bottom doors or side doors. Add some paint, stains, weathering (don't be afraid to carve up the tops of those side boards to simulate damage), and lettering, if desired, and you'll have a pretty good truss rod gondola. So, maybe next time a boxcar...



Figure 3

Duane Richardson's article starting on page 13 was part of a workshop. He put together this parts list:

- 1 package ~ 4x12's
- 1 package ~ 4x6's
- 1 package ~ 2x6's
- .012 Brass wire ~ 1 package (you can share this with a friend since we won't need much)
- 1 set of trucks
- 1 set of couplers (and mounting screws if not included)
- 1 set of brake details (only a brake cylinder if you want the basics)
- 1 brake wheel (a package has a wheels so they can be shared too)



- 1 decal set or dry transfers
- 1 package of grab irons (a package has a couple of sets so they can be shared too)
- 1 set of couplers
- 1 set of NBW's (Nut, Bolt, Washer castings). This will be listed with the size of nut and washer. Nut size isn't as important as the washer. You will want something in the 4 to 6 inch range. (unless you are really going after a certain prototype and then you will need to consult a set of plans for that car to see what size you need. Or better yet, measure one yourself if possible).
- 1 flat piece of brass or lead (especially if you want to run the car without a load) this should not be very thick but you will need some weight to help the car track correctly.
- 1 casting or set of castings for a load (some castings can be drilled out to add weight).

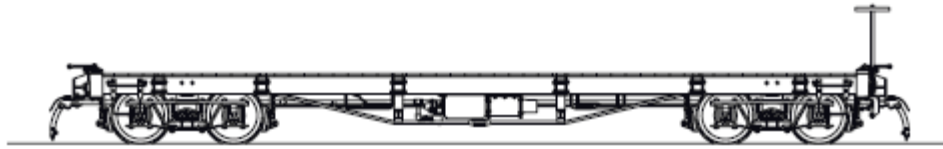

THE ANATOMY OF A FLAT CAR

By Duane Richardson, MMR

Website: <http://www.purgatoryanddevilriver.com>

Published by permission—Originally a presentation to NMRA Lone Star Region, Division 3

http://www.lonestarregion.com/div_3/launch.shtml

This is the basic underside of a wood framed flat car. Let's go over each of the pieces.

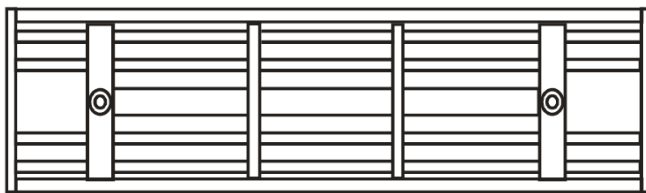

First, the **End Sills**. This is a large beam where all the other sills are joined to form the ends of the car.

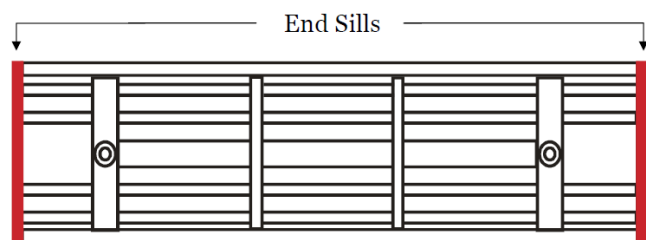

On the prototype, the sills were joined together with mortise and tenon joinery. This is where a hole is created in the end sill (the mortise) and a tab is left on the other piece (the tenon) The tenon slides into the mortise and the two pieces are fastened together. On our models we just butt joint the two pieces together with glue.

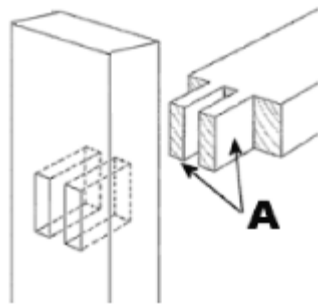

Next, the **Side Sills**. This is another large beam that makes up the entire side of the car.

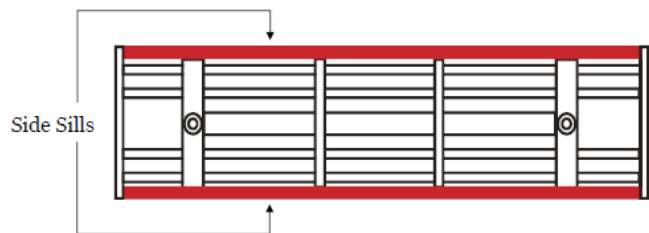

On the prototype, this beam supports the ends of the deck boards and is a good portion of the strength of the car. The side sill is the visible side of the car where all the lettering is and where any stake pockets and grab irons are bolted.

The **Intermediate Sills** are beams that are smaller than the side sills. While slightly smaller, they support the section between the side sills and the center sill.

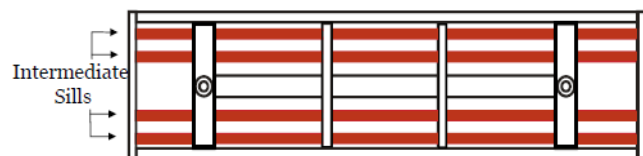

On the prototype, there are usually 4 intermediate sills on a car. They are positioned in two pairs. They support the middle of the car and provide a home for most of the cars appliances such as the brake system. The location of the brake system depends on the railroad and the manufacturer of the car.

Typically, the **brake cylinder** would be located somewhere in the location of the green box. This is the tank for the cars air brakes. Pipes will run to and from this tank. The supply line comes in and a rod will come out one side to actuate the brakes of the car.

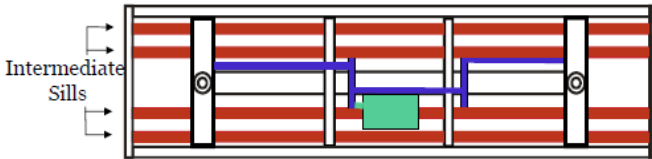

In this VERY basic illustration, the air pushes the rod out of the tank (the arrow). This will push this lever which pulls a chain or rod that draws in the brake shoes on one truck as well as pulling another lever that then pulls the brake shoes in on the other truck.

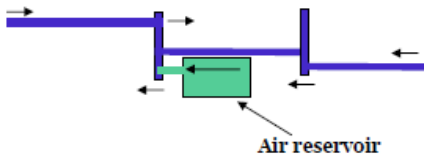
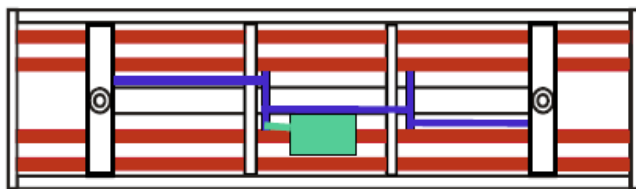

The **Center Sill** is the largest beam and forms the backbone of the car.

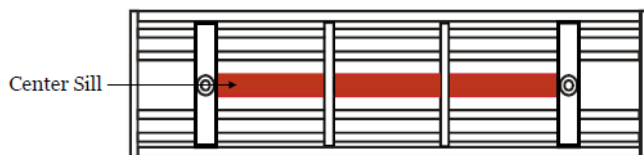

On the prototype there are usually beams bolted together to make up the center sill. This is where almost all of the stress of the pulling and pushing on a car goes. Where the other sills make up a good portion of the integrity of the car, the center sill is the very heart of the car. The largest portion of the stress on the car is handled here. Think of it like this, all the other sills hold the load, the center sill where the pushing and pulling takes place.

The **Draft Gear** is where the couplers mount to the car. The draft gear assembly is mounted to the cars end & intermediate sills, the deck and, most importantly, to the center sill.

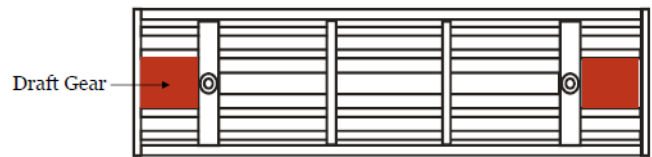

Pulling heavy trains up steep grades put a LOT of stress on this part of a car. It was not uncommon at all for this area to fail under a load. On our models this is a simple coupler box (like a Kadee box and coupler). On most model freight cars this is molded in place. Many modelers will cut this off and mount a Kadee box with a screw.

The **Bolsters** are cross members on the underside of a car body and in the center of a truck, through which the weight is transmitted.

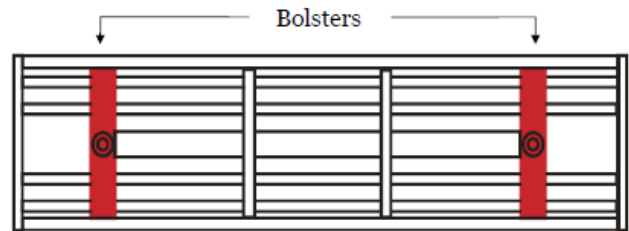

On the prototype the bolsters carry the body and truck center plates, the body bolster resting on the truck bolster.

The **Needle beams** lie across the various sills of the car. This is the first layer of support for the truss rods of the car.

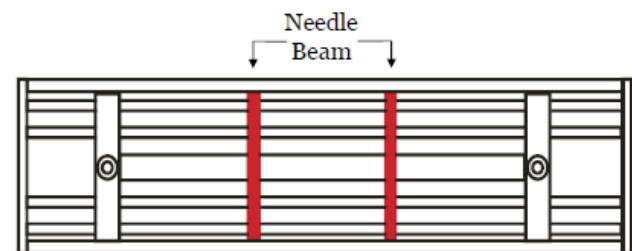

On the prototype the needle beam will have several holes drilled through it to allow parts of the

The **Queen Post** is a metal casting that mounts to the needle beam. The end has a U shape to accept the truss rod.

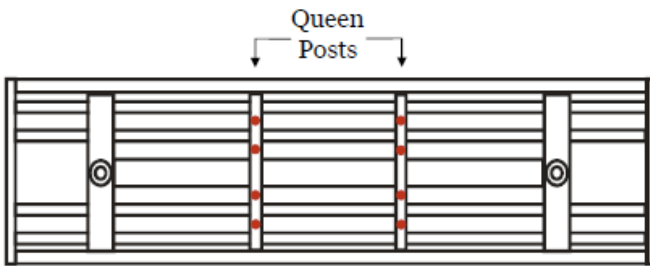

In wooden car construction, one of a pair of vertical posts against which a truss rod bears. When one post only is used, it is called a King Post. Such posts are used for the truss rods under car bodies.

The **Truss Rods** are metal rods that run the length of the car in two sections to keep the car flat. In the middle was a Turnbuckle.

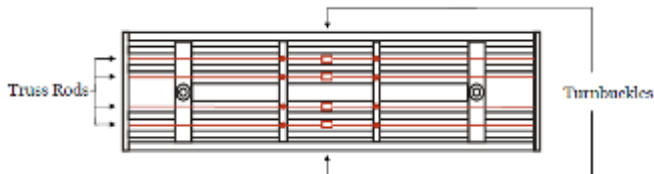

In wooden car construction, the weight of the load will cause the car to sag in the middle. A rod is threaded on each end. This allows the rod to be bolted to the end sill and threaded into one end of a turnbuckle. The turn buckle can be turned to tighten or loosen the rod and thus flatten out the car. It was common on many railroads to run a board through the opening of each turnbuckle to keep them from turning themselves due to vibration. The turnbuckle area was a favorite spot for hobo's to ride. Thus the term, "Riding the rods."

The only thing left to do is turn the car over, add the deck, mount the trucks, add stake pockets (if necessary) and the car is ready for paint. Most prototypes did not paint the deck lumber. It would normally need replacing long before it would rot.

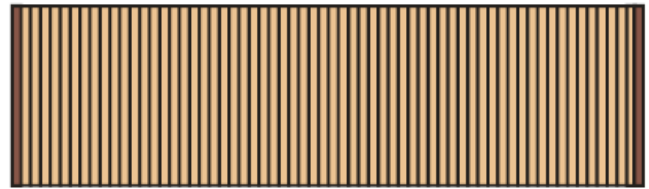

The **deck boards** vary in thickness and width depending on the car builder. Some were butt jointed together. This will leave a bit of a gap as the wood dries but this allows water to drain off the deck. Many of the car floors were joined with tongue and groove joints.



One last note...If you want to get a head start on the project, take 3 pieces of the 4x12 stock and paint all the edges and one of the wide edges with an acrylic paint. Leave one wide face unpainted (this will be the inside edge of the car). To do this, I lightly sand the wood to knock off any fuzz. Then I like to put a little paint on a paper towel or rag and DRAG the wood through. DO NOT push the wood through. Remember, it's thin and it WILL break if you push it through. Place some weight on the wood while it dries to keep it flat.

On my models, I paint the wood before I assemble the car. That way I can put weight on the wood and make it dry flat. If you paint it after the car is assembled there is a possibility that the wood can warp I also find it's easier to paint and letter the car and then add the stake pockets. I mark their location so I don't get the lettering in the wrong spot. It's also easier to do some preliminary weathering without them.

The last thing I do is to add the grab irons on the corners and the break wheel.

That looks pretty easy doesn't it? It is and the best part is that this is the base for almost all other freight cars. A gondola is a flat car with sides. A box car is a flat car with taller walls and a roof.

(The following pages have plans from Duane's workshop to build a flat car.)

This plan should be to scale when printed out full size—but check before proceeding!

Many thanks to **Duane Richardson** and the **Lone Star Region, Division 3**, for sharing this clinic.

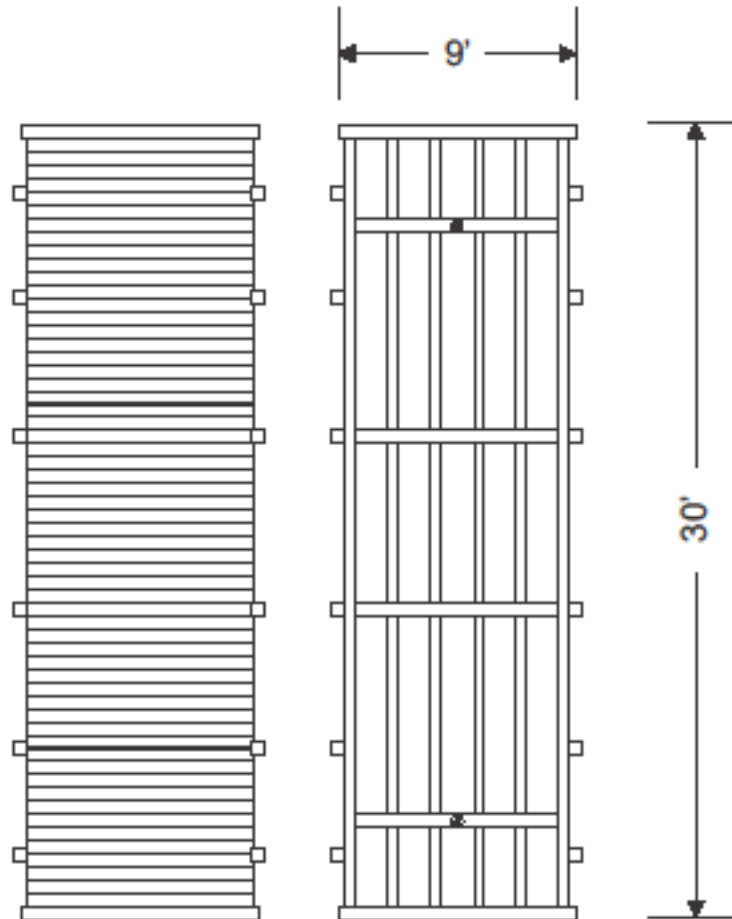

HO Scale

Plans loosely based on a D&RGW narrow gauge flat car. The **Denver Public Library** has a photo: http://digital.denverlibrary.org/cdm4/item_viewer.php?CISOROOT=/p15330coll22&CISOPTR=47296&CISOBX=1&REC=4

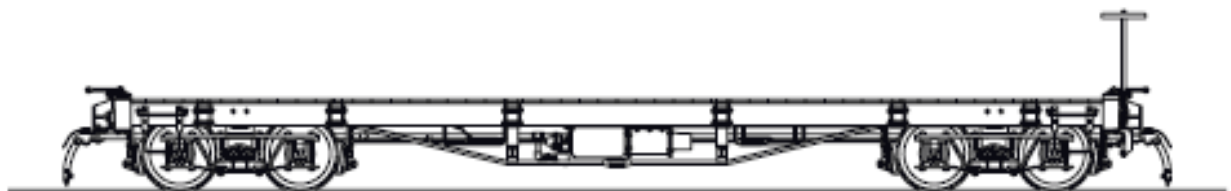

This plan should be to scale when printed out full size—but check before proceeding!

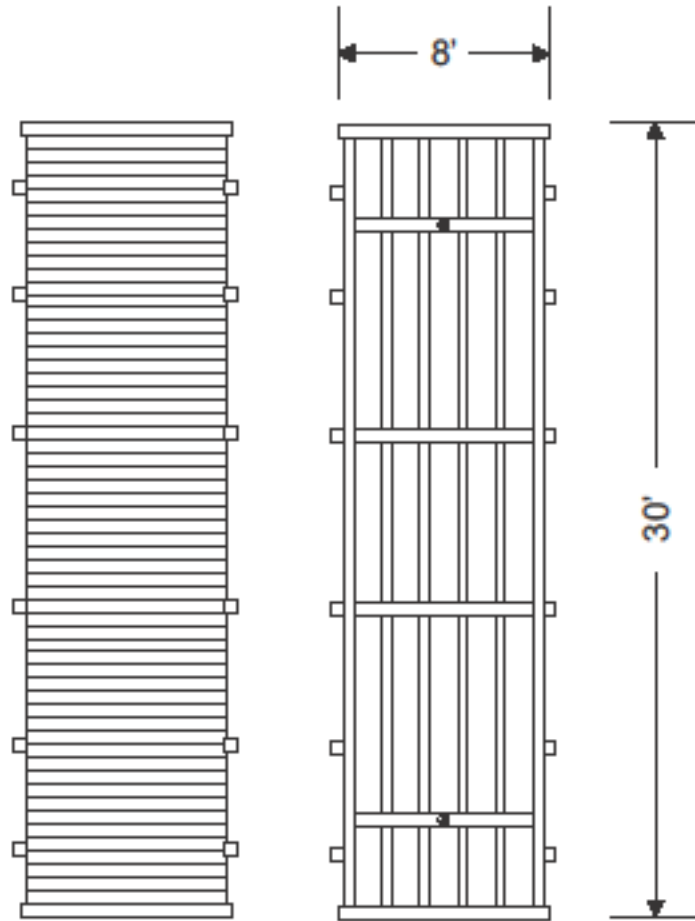

HOn3 Scale

This plan should be to scale when printed out full size—but check before proceeding!

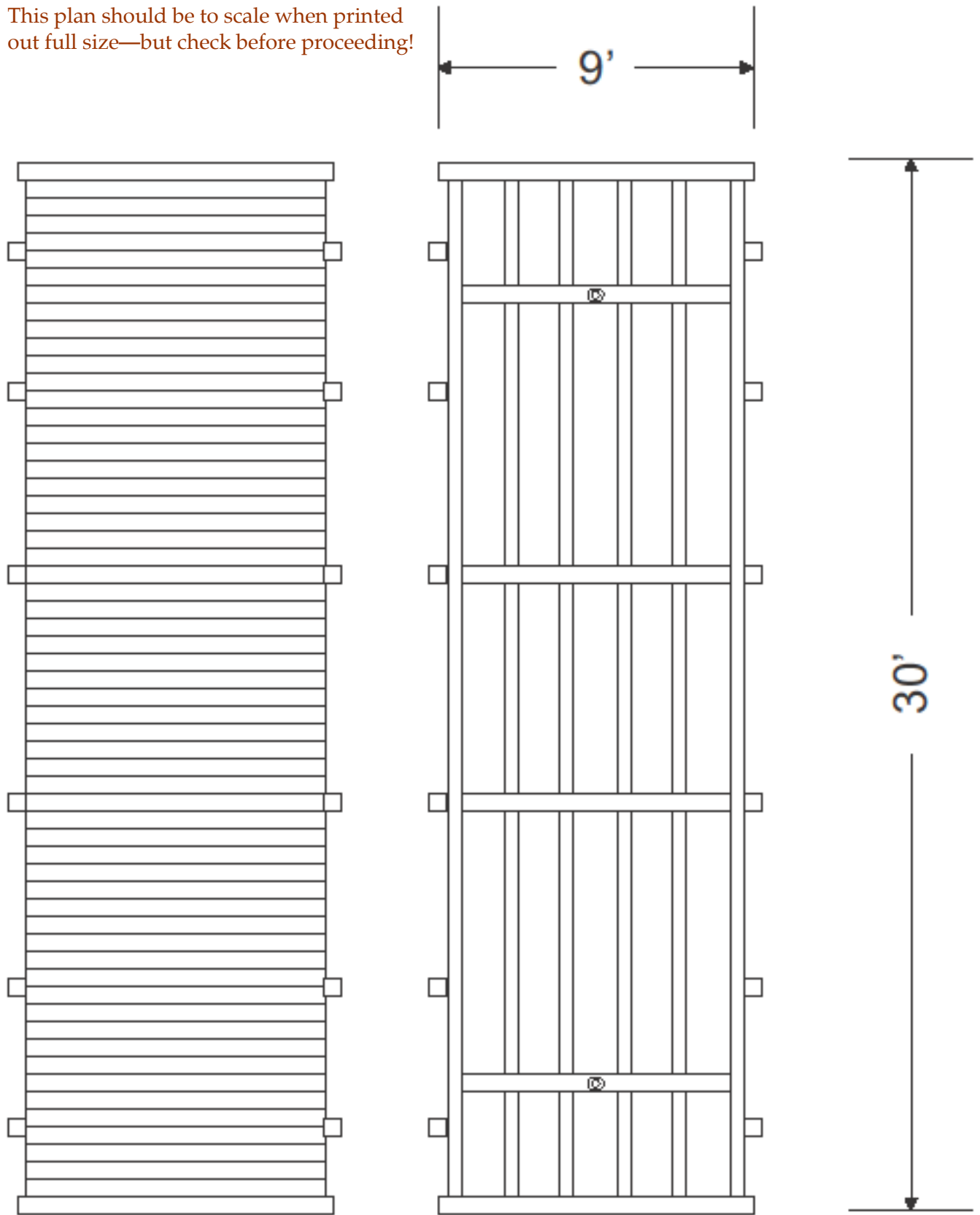

O Scale

This plan should be to scale when printed out full size—but check before proceeding!

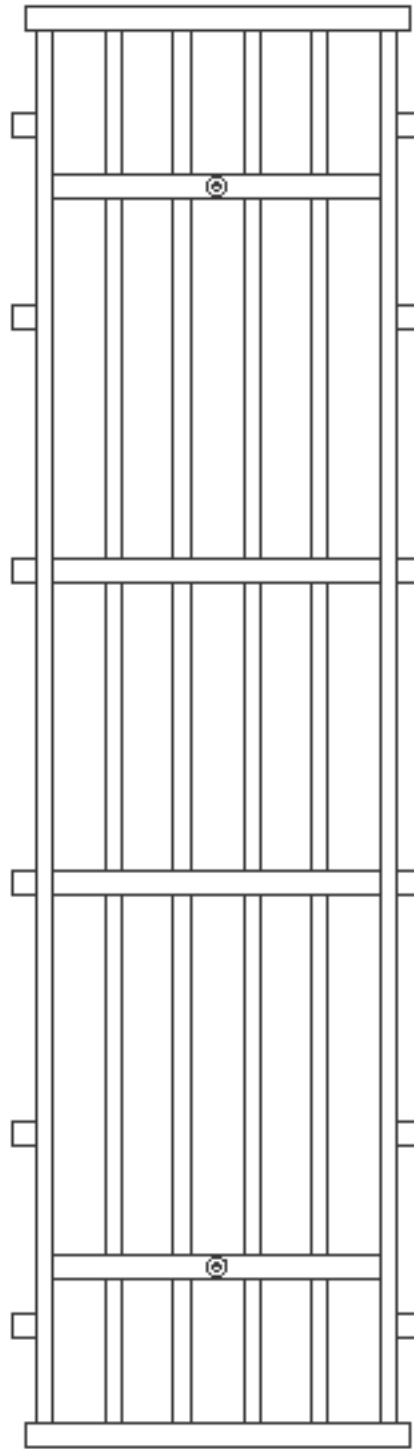
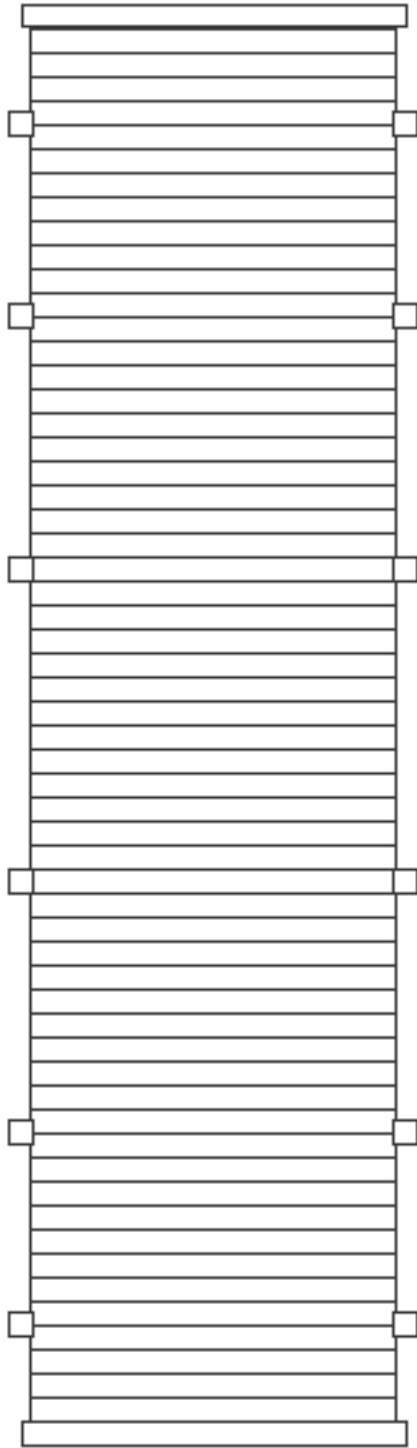
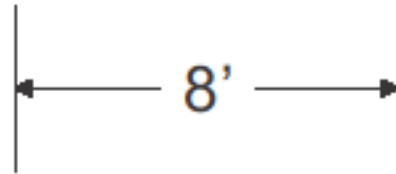

On3 / On30 Scale

This plan should be to scale when printed out full size—but check before proceeding!

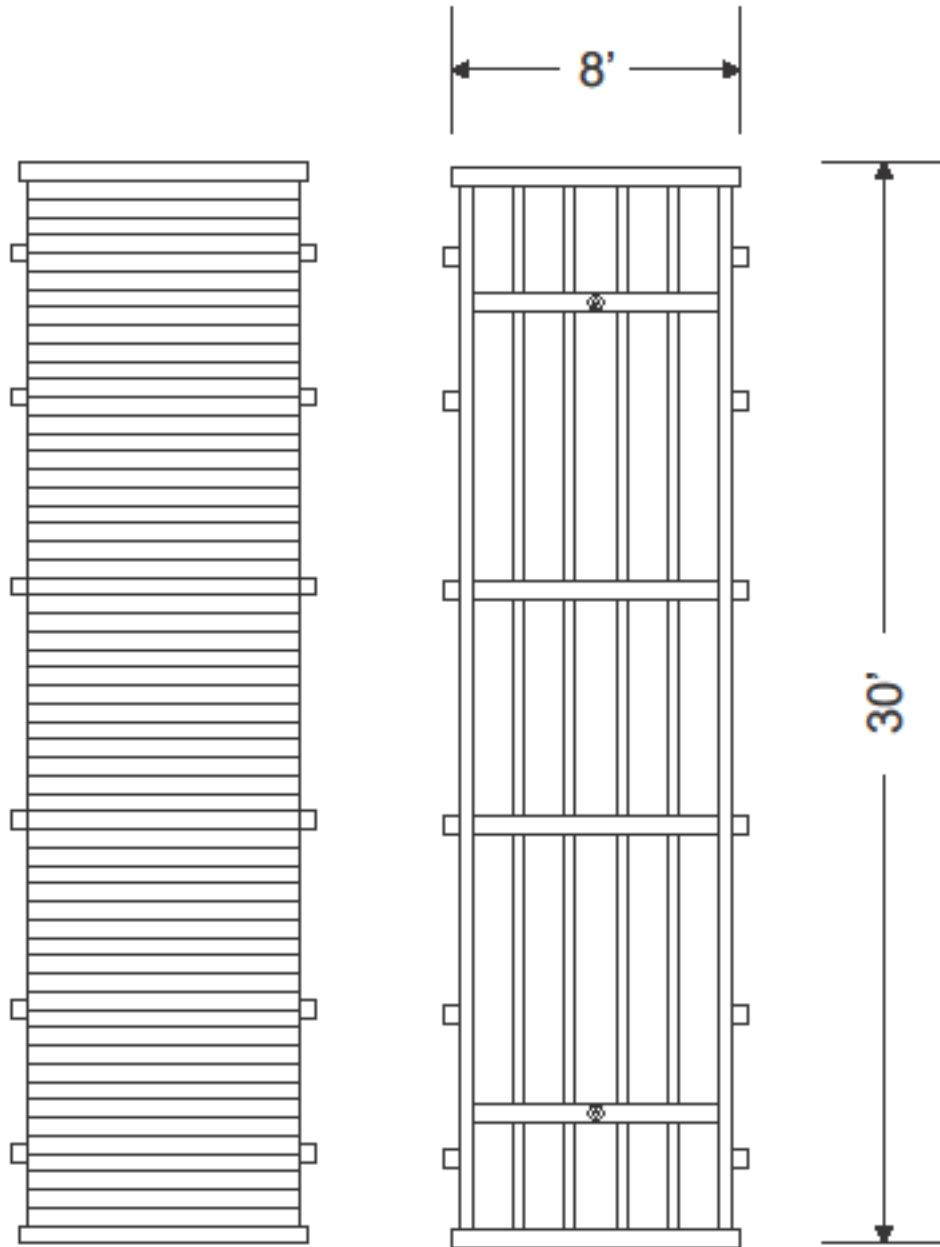

Sn3 Scale

This plan should be to scale when printed
out full size—but check before proceeding!

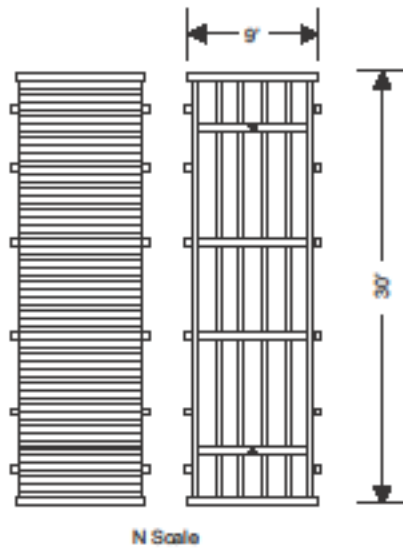

Rusty Metal and Weathered Wood; *Scratch-building a Carson and Colorado Flat Car in On3*

By Chris Butler

Photographs and Illustrations by the author ~ Reprinted with permission

Part 1 – Why Were Narrow Gauge Freight Cars Built That Way?

Some while ago, I decided that it would not be too difficult to scratch-build a simple narrow gauge flat car in O-Scale and be a really interesting project to boot. A few pieces of strip basswood, commercial trucks and I might even install the brake rigging - hey, what could be easier and simpler? Well, this is a story about a little project that grew and grew. Sound familiar?

ing the plans for the car but this time in O-Scale using CorelDraw 9. It's not until one goes through an exercise such as this, that the all important (and often missing) details become all too apparent. In retrospect, the original 1/32nd plans were quite scant in terms of details. Fortunately, some plans and renovation photos in two issues of the NGSL Gazette - the Nov/Dec 2001 (North Shore Railroad 3'



Fig. 1. The author's completed 22' On3 flat car.

Scale Plans

I model small prototypes and so I based my design on the 1/32nd scale plans of the circa 1875 Carson & Colorado 22' long, 3' gauge flat car (which ran originally between Carson City, Nevada and Keeler, California) that appeared in the Dec 1999 / Jan 2000 issue of Finescale Railroader. This is published free of charge and available openly for download on the Internet at <http://www.finescalerr.com/>. The problem was that I wanted to model it in O-Scale. A few days later (Well OK, weeks later) and I had finished redraw-

ing the plans for the car) and the May/June 2002 (Diamond and Caldor 3' gauge flat car) helped fill in most of the missing information. Where would we be without back issues of the NGSL Gazette, eh?

Although re-drawing the plans was a lot of work, it was well worth it in terms of a

“learning” experience and, I was really happy with the end result. It was around this time, I realized that I had to make a decision – either stick with my original vision and build a quick and simple piece of On3 rolling stock or build something better. I picked the latter option.

Carson and Colorado Rail Road Flatcar #105

Drawn: July 18, 2003,
Revised: August 21, 2003.

Scale: 1/4 inch = 1 foot (1/48")
Copyright © 2003 Chris Butler

This plan should be to scale when printed out full size—but check before proceeding!

It is exactly 22' over the end beams.

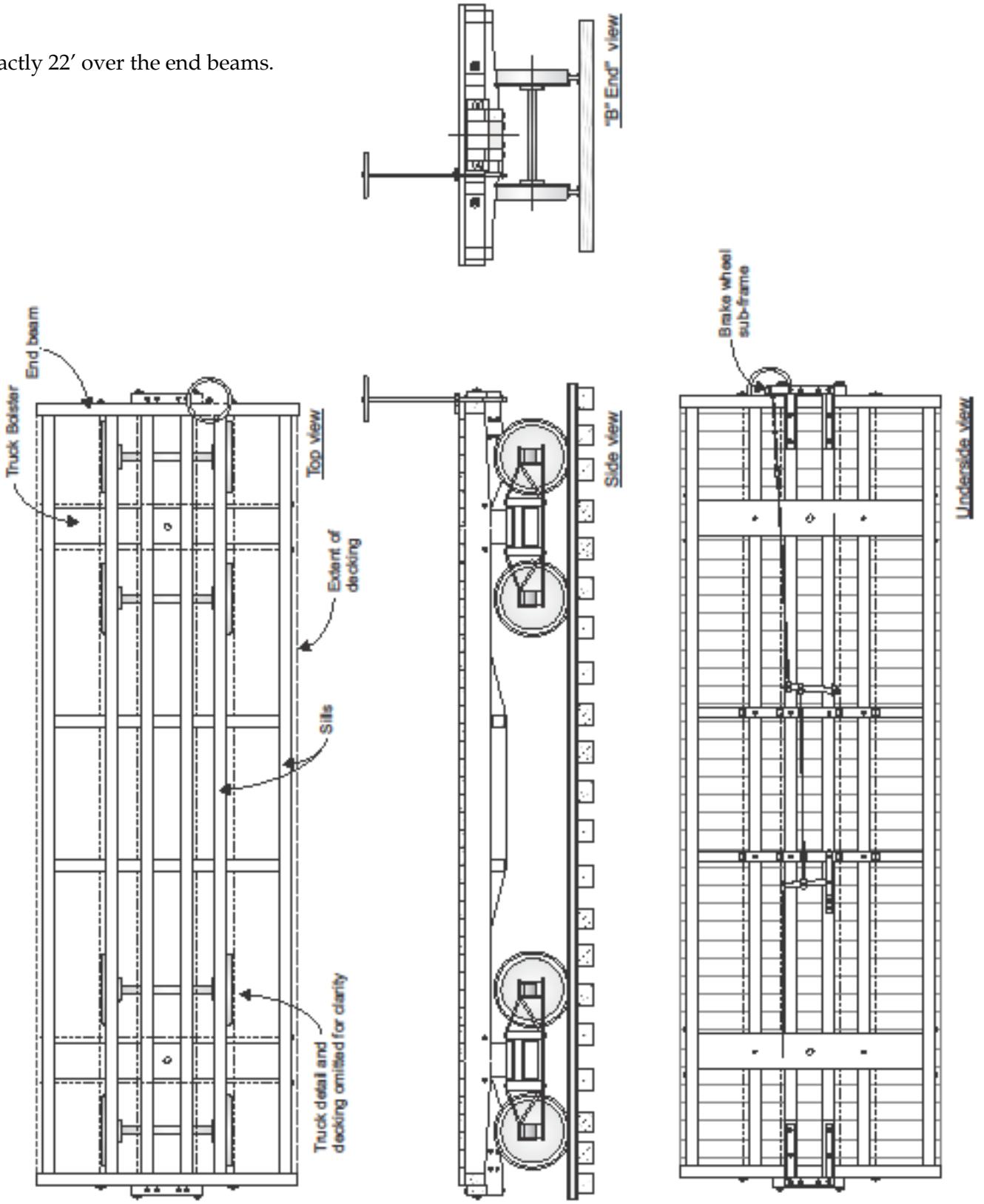

Truss Rods

As I studied the drawings of a few flat cars, it became clear to me that the truss rods that run from end-to-end (lengthwise) perform multiple roles. The prototype connected the sill sections into the end beams with simple mortise joints. No yellow glue here because once tensioned, the truss rods hold the car together and prevent the end beams from becoming detached. The clever parts are the needle beams. These lateral beams create an open triangulated girder and force any weight that's placed in between the trucks out toward the end beams. The un-sung hero's here are those massive washers and nuts that are threaded on to the ends of the rods. Don't believe me? All of this can be proved by applying simple trigonometry. In mechanical structures, triangles really rule...

The other important role that the lateral truss rods perform is to effectively transfer any pulling or pushing forces from one coupler to its counterpart at the other end of the car. The side-to-side or Transverse rods form a similar triangulated girder but they strengthen the side sills by deflecting any side load toward the two truck pivot points.

Brake Rigging

After installing the truss rods, I decided to go back to my reference books and settle on a simple approach to the problem of the brake rigging. Since my car is supposed to be an early prototype, I decided that I'd not include air brakes and just go with a typical early mechanical linkage. I'm fairly certain the prototype didn't use them either.

The brake rigging arrangement that these old cars used was truly ingenious; incredibly simple and easy to maintain. When the brake wheel is turned, the chain tightens which applies the brakes to the "B"

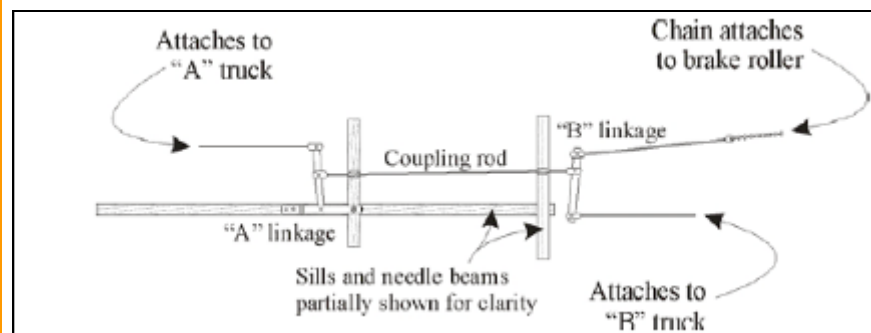

Fig. 3. The brake rigging arrangement the author used on his 22' C&C flat car. Note that the "B" truck is located at the "B" or brake wheel end of the car.

truck via the "B" linkage. Since the coupling rod cannot be stretched, the "A" linkage starts to move in a clockwise direction (because it's fixed to the chassis at one end) which applies the brakes to the "A" truck. Notice that this rigging arrangement even takes into account the clockwise / anti-clockwise movement of the trucks when the car goes around a curve... The other thing that's apparent here is that it's quite feasible to repair this arrangement with minimal tools, even if you were stuck miles from a repair facility. Adding an airbrake to this system would simply require a third linkage system, air hoses and a brake cylinder. As an aside, I noticed that at least the one of the standard gauge wooden Cabooses at the Smiths Falls Railway museum had a similar (but alas, not identical) brake roller arrangement.

Shiplap Decking

I've built a few wooden decks in my time (you know, the usual 2x12" joists on 16" centers with 2x6" decking either nailed or screwed to it) and it's always puzzled me how the under frames on freight cars could ever provide adequate support. For example, on the C&C narrow gauge prototype car, there's a gap of approximately 22" between the outer sill and the closest center sill. How can this work? We'd never build a deck with joists on 22" centers because the decking

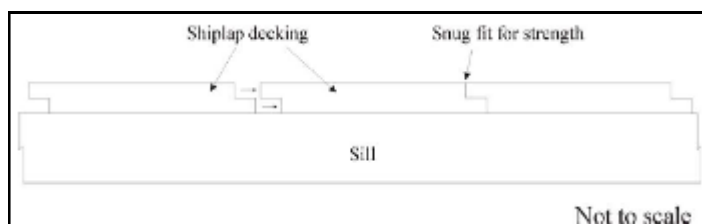

Fig. 4. The Shiplap decking

would sag. The answer to this is in the way the decking sections are shaped. Unlike our residential decks,

the freight car builders used shiplap decking. Due to its shape, each freight car decking section overlaps its neighbor on its edges.

Shiplap design provides greater strength because once the decking sections are installed it effectively makes them one big continuous sheet – in our case, 22'x7'. If you think about it, older houses employ a similar arrangement with tongue and groove flooring.

Part 2 – Let's Get Down To Work!

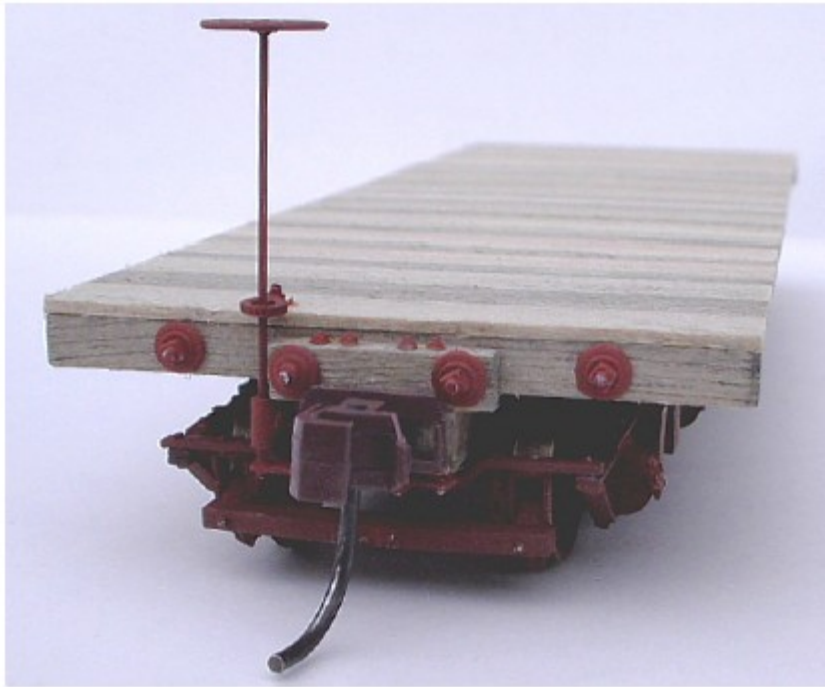

Fig. 1. "B" end view of the author's completed 22' On3 flat

We explored the basic design elements of a typical narrow gauge flat car. With that behind us now, let's get started and build an O scale model of it!

Flat car jig and under frame construction

In order ensure that I built a square and repeatable under frame for the flat car frame a simple styrene jig was constructed. After all, I might want to use the jig to build another under frame for say, a caboose or a boxcar. I used a piece of scrap 0.040" thick sheet and marked out the location of the sills and end beams. When this was done, I glued some square dimensional styrene rod to it to act as guides for the sills. I also used odd pieces of scrap styrene to ensure that the sills were correctly spaced. The end result didn't look pretty however, it was very functional and filled the bill nicely.

So much for the jig, the next problem was "Where can I obtain O-Scale basswood?" The answer was quite simple. In the past, I used to model in HO-Scale and as a consequence, I had lots of Northeastern dimensional stock on hand. The only thing I had to do was to ignore its equivalent HO size and think of it as regular dimensional stock.

Sounds simple, right? Well, I built a basswood prototype and tore the jig apart and rebuilt it three times over (with freshly cut basswood and corresponding alterations to the drawings) before I was happy with it.

For the center sills, I cut 4 lengths of HO-Scale 8x12" stock (roughly 5x7" in O-Scale) and two lengths for the end beams. Next, I cut the side sills from 3/32" x 1/4" basswood stock and are fully sanded the angled tapers that go from the truck bolsters to the end beams.

All of the sills were "gang sanded" on my home made sanding jig to ensure that they all finished up square and the same length. I did the same with the end beams. Once I was happy with the final dimensions, I stained them with a light wash of black shoe dye and Isopropyl alcohol mix. When they were dry, I loaded the pieces into the jig, carefully applied some yellow glue and inserted the wedges. I remem-

bered reading one time that yellow glue sets up stronger if it's compressed while it's drying. It must have something to do with the glued getting squeezed into the fibers of the wood. Anyway, hence the wooden wedges. To make absolutely certain that everything was flat, I applied a heavy weight to the frame while it was setting.

Once the frame was dry, I made up two bolster sections for the trucks from 1/8" x 9/32" basswood stock, stained them and glued them in place. Note that I de-

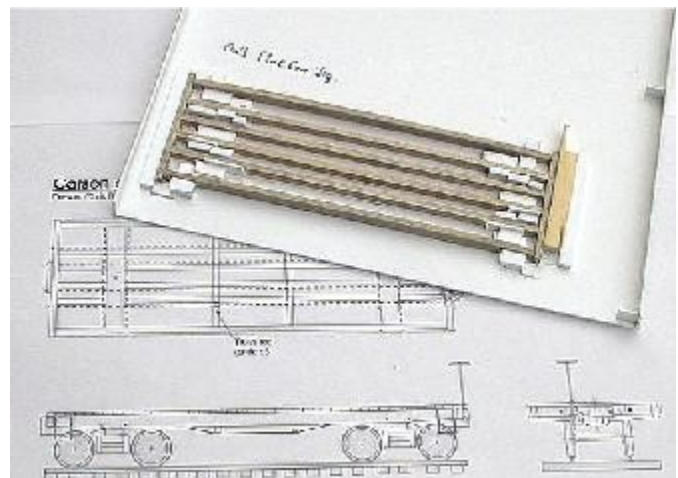

Fig. 2. The completed jig with the end beams and sills in place – note the wooden wedges at the right-hand end.

viated here as the prototype used what appears to be cast metal bolsters.

Needle beams and Buffer blocks

Next, I built the needle beams from the 8 x 12" HO scale basswood and glued them in place. I made up two buffer blocks for the end beams by cutting pieces of the HO basswood and sanding their thickness a little. I then followed the previously described sequences for staining and gluing.

Draft Timbers

The next step was to make up four identical draft timbers by carefully cutting and sanding some of the HO 8"x12" basswood. Note the notch for the buffer block

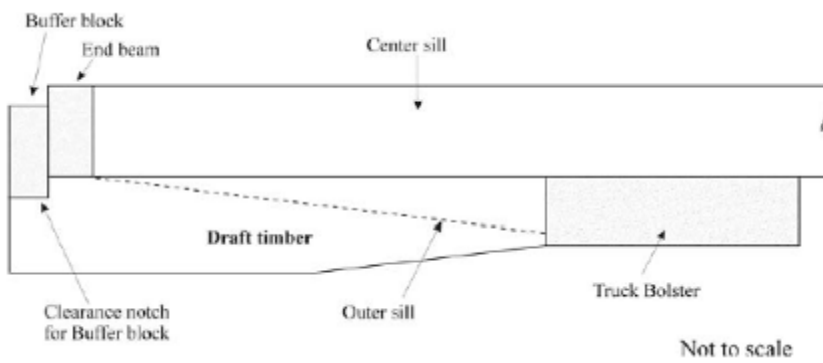

Fig. 3. Draft timber details – 4 required.

clearance and the taper as it meets up with the bolster.

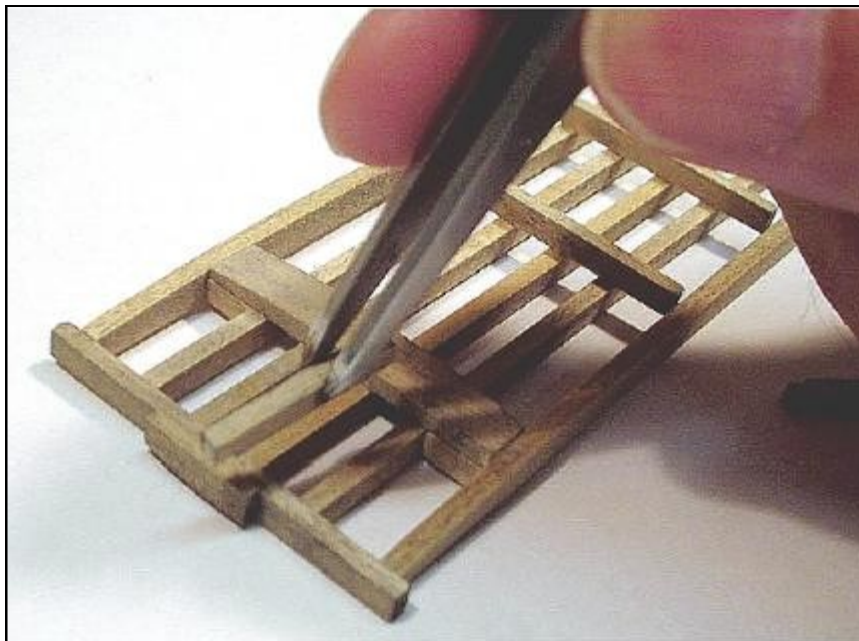

Fig. 4. Installing the completed draft timbers.

Once the timbers were ready, I stained them and when they were dry, I carefully glued them in place.

Couplers

I decided to use Kay Dee #807 On3 couplers. If you've used Kay Dee's #5 HO couplers, these work on the same principle however, the coupler knuckle is made from a slippery Delrin plastic (moulded in a brown or black colour depending on the model) with a metal uncoupling trip pin. Using Delrin is a good idea because the color is right and the couplers couple together very easily. The other big difference between these and the #5 HO couplers is the self-centering design and of course the overall size. The coupler pockets were narrowed to roughly 9 scale inches as per

Kay Dee's instructions so they'd fit between the center sill sections and then they were assembled and installed. Even after narrowing the pockets, I found it necessary to hollow out the draft timbers a little so the couplers would "swing" from side to side properly.

Truss Rods

I built my truss rods from 0.022" brass rod. The prototype appeared to have saddles where the truss rods touched up against the underside of the needle beams. I built my saddles (eight of them) from 1/64" x 1/32" brass rod and carefully soldered them to the brass rod. The truss rods were cleaned up with diluted dish washing detergent and airbrushed with my "old rust" mix – a blend of Floquil Rust and Zinc Chromate Primer. Once dry, they were carefully assembled onto the flat car. I then drilled 0.025" holes into the end beams and glued each truss rod saddle in place with ACC. From what I could see on the photographs and drawings I had to hand, turnbuckles were not used on these cars. Lastly, I installed eight pre-airbrushed Grandt Line #16 2 1/2" NBW's onto the two end beams to represent the end-to-end tensioning truss-rod system.

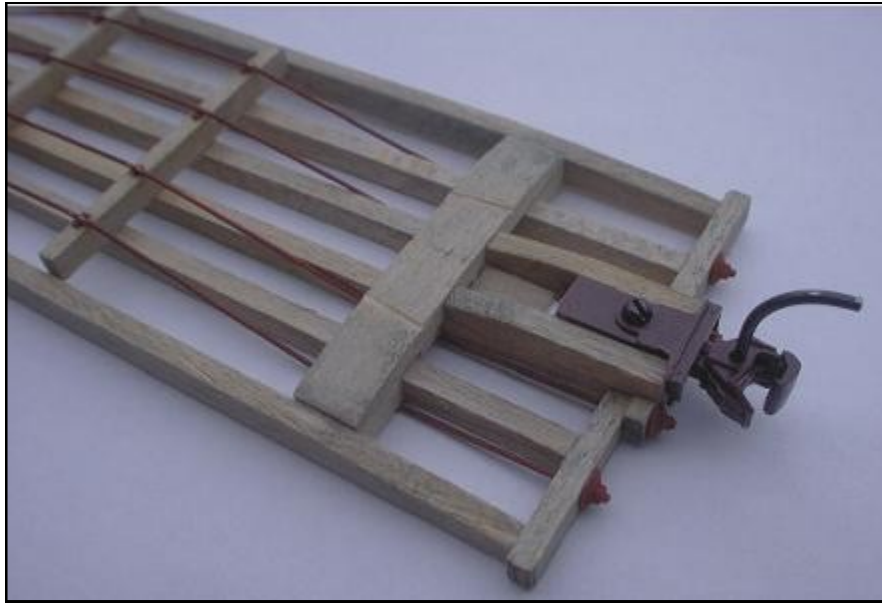

Fig. 5. The completed truss rods installed – note the saddles and NBW castings.

unsophisticated – 18 Watts and not temperature controlled, I soldered some of the joints and used ACC on the others so the thing wouldn't fall apart while I was building it. It was then I discovered that ACC isn't all that strong (especially if you bake it at 200°F!) and consequently devised plan "B".

Plan "B" entailed soldering all the parts. Since I was soldering parts that were often only a couple of millimeters from another solder joint, the problem was to prevent the initial joints from becoming unsoldered as I added another part. A few years back, I remembered reading about using wet tissue paper as a heat shield. I used this approach and found it worked very effectively.

Part 3 – Finishing

Once I finished beating, bending and filing the rigging parts, I laid them out on top of the plans which

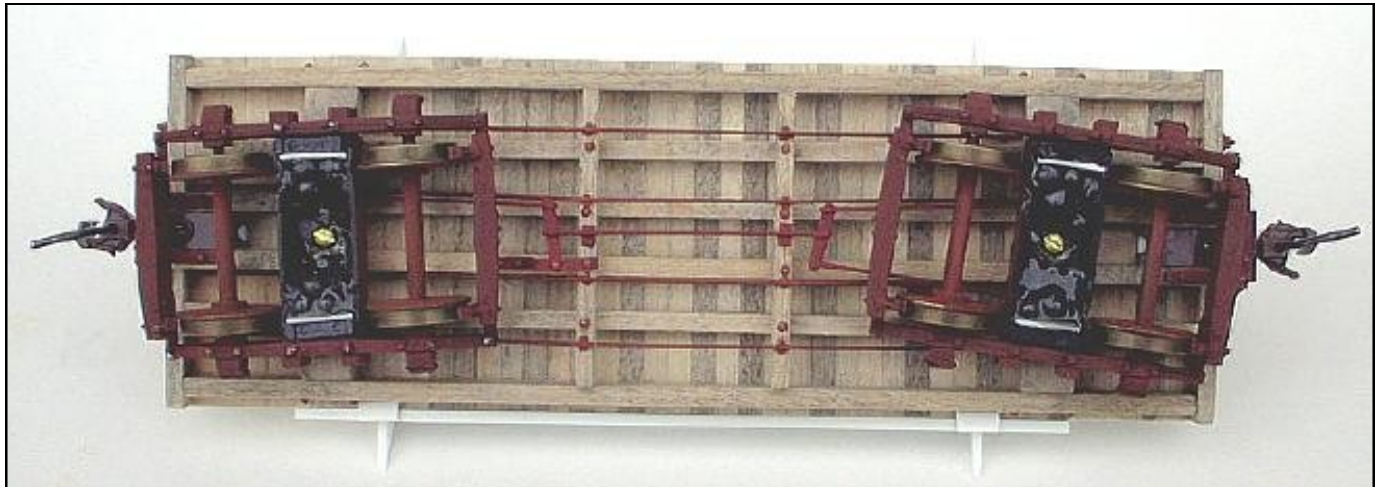

Fig. 1. Underside view of the author's completed flat car.

Now we've started, let's complete the model.

Brake Rigging

I made the parts from 0.022" brass rod and 1/64th (~0.016") x 1/16th" K&S brass strip – available from most local hobby stores. The coupling rods were shaped at their linkage ends by simply hammering the end flat on a smooth concrete floor. OK, on to the soldering (remember guys, there's an 'L' in soldering...). Anyway, since my soldering iron is extremely

were attached to a scrap piece of wood with masking tape. Now I could see where all the bits were located. One by one, I carefully fluxed the joints and sparingly applied solder. When I had two adjacent joints, I simply used the wet tissue paper to prevent the joint from coming undone. Who needs a high-tech resistance soldering setup anyway? Well, one would be nice! Man, this project is growing.

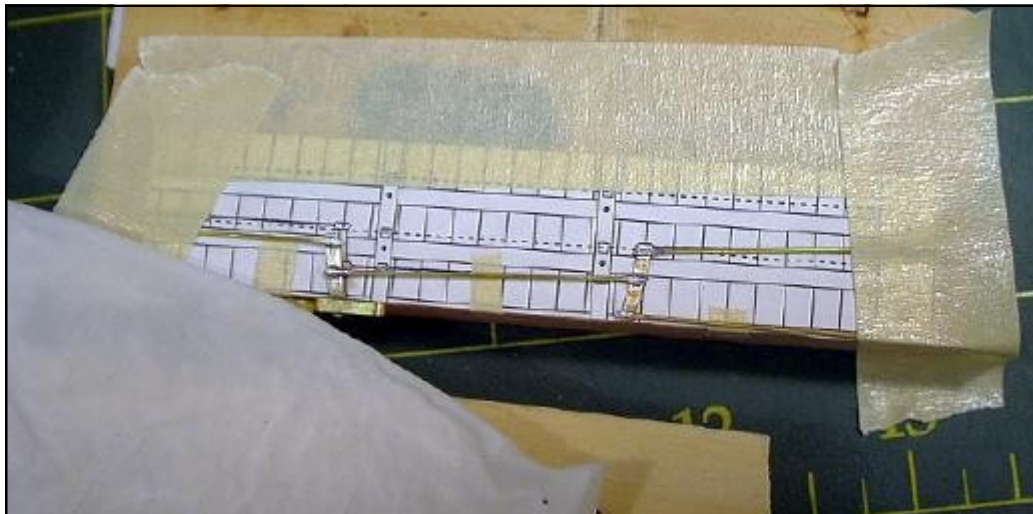

Fig. 2. Assembling the brake rigging parts – note the wet tissue paper and masking tape

Prior to installation on the car, I carefully washed the entire assembly in dish washing detergent and air-brushed it with my old rust formula.

Once dry, I super-glued a few pre-airbrushed Grandt Line #99 1 5/8" NBW (NBW - Nut, Bolt, Washer) castings to the rigging. The final result was well worth the extra effort and this time it didn't fall apart. Triangles and soldering (with an "L" rule!

Once the main rigging was completed; I turned my attention to the small sub-frame located at the "B" end of the car on top of the draft timbers. This supports the brake wheel shaft and roller bar for the flexible chain linkage. For the brake shaft and support frame, I

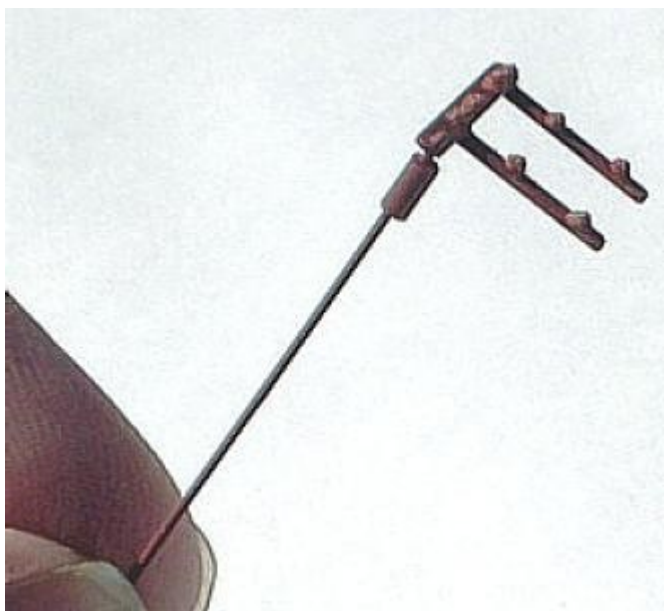

Fig. 3. Brake shaft and Roller bar "sub-frame".

made the parts from 0.022" brass rod and 1/64th (~0.016") x 1/16th" K&S brass strip which I soldered together.

I used a Grandt Line #94 15" Lovested brake wheel, ratchet and pawl set. I made the roller bar from some 0.025" internal diameter brass tube cut to roughly 6" scale inches in length. This was ACC'd to the brake shaft. Next, I added some NBW castings and the entire subassembly was then washed, dried

and airbrushed with my old rust mix.

Trucks

I used the MacLeod Western T-3 Carter Bros. 4' trucks. These are simple styrene kits and went together easily. The brake beams however were another matter. I used Foothill Model Works FMW-4000 wooden brake beams which are designed to be used with the MacLeod Western trucks. These beams are a work of art but extremely fragile and so I spent quite a bit of time repairing them! Be sure to take extreme care in removing them from the sprue as this was where I encountered most of my problems. The prototype used body hung brake shoes however, this is close to impossible to replicate in O-Scale and so mine are truck-mounted as per the FMW instructions.

I cleaned up the castings and the NWSL 24" wheels and airbrushed them with my "old rust" mix – a blend of Floquil Rust and Floquil Zinc Chromate Primer. For the wheel sets, I cut up some masking tape and masked the treads prior to airbrushing them. Once they were dry I brushed the wheel sets and trucks with weathering chalks and dry brushed the details with Polly S Reefer white. The final step was to increase the truck's weight with lead shot and some 2-part epoxy. The last step really makes a difference in how the trucks roll. This is important because on a flat car, there are not too many places we can hide weights!

Decking

The decking was HO Scale Northeastern 3" x 10" basswood. This works out to be almost a 2" x

6" (finished dimensions) in O-scale (1 7/8" x 5 7/8") – close enough. The Northeastern basswood was scribed (with an old Atlas Snap saw) to represent a grain and stained with a very light wash of black shoe dye and Isopropyl alcohol mix in order to make it look like weathered wood. In order to add some interest, the basswood strips were stained with various shades of the shoe dye / Isopropyl mix. Once dry, these were cut into scale 7' 4" lengths and carefully glued to the flat car frame. I used a small square to ensure correct alignment. The finished pieces were butted up close together to represent the "Z" ship-lap decking because I didn't want any daylight showing through the gaps.

Paint and finishing details

I pre-airbrushed some Grandt Line #99 1 5/8" NBW castings with my old rust mix for the Needle beams where they connect to the sills. I did the same thing with the 8 NBW castings for the buffer blocks. These were then glued onto the under frame with ACC. Finally, I installed the completed MacLeod Western T-3 Carter Bros. trucks described earlier to the bolsters

with two 1/4 inch long x 1/72 brass pan head screws. As I wanted a car that had been used a lot and was well weathered, I used a dry brushing technique with a small Nylon brush that I had "modified" (ruined) so as to make its individual hairs 'splay out'. The Floquil paint (Boxcar red) was applied to the previously stained outer sills to simulate peeling paint.

Conclusion

I really enjoyed building this simple flat car and I'm really keen to build a Caboose using the same construction techniques and jig.

If you'd like to construct this flat car (or something similar), please send me an email at ca.butler@sympatico.ca and I'll respond with scale drawings in CorelDraw 9 format, DXF format and un-scaled drawings in hi-resolution JPEG formats. Just let me know.

This is the final part in the series and I hope you enjoyed reading it. Until next time...

Southern Pacific CS-30 ~ 36 Foot Flat Car

Forward by Gary Ray

Excerpts from Anthony W. Thompson's Southern Pacific Freight Cars

Volume 3: Automobile Cars and Flat Cars; pages 154, 168 to 171, 398

Published with permission

I am modeling Southern Pacific in 1926 and hope to meet the modeling challenge by building a S.P. CS-30 flat car. Mr. Thompson's five volume set has information covering cars from 1890's through the 1960's. I appreciate his willingness to share information with our division.

Tony says that the CS-30 was a culmination of SP wood flat car design. The cars were constructed in 1902 by American Car & Foundry. SP had 250 numbered 79500-79749; CP 250 numbered 79750-79999; and T&NO 500 numbered 20100-20599.

Excerpted from SP Freight Cars: "The last of the 19th century truss-rod flat cars on the Southern Pacific was the CS-30 design, now upgraded to 40 tons and continuing the 36-foot length already standard for several years.

Note the complex shape of the cast-steel body bolster. "

The drawing on the next page "dated December 21, 1901, represents design approaches predating the Harri-man period."

The "lettering diagram, adopted May 22, 1922, and with a single revision in September of that year, shows lettering of the 1920's on the CS-30 flat car. It is interesting that the same "3-foot concentrated load" warning appears on this car as was applied to much later cars. That warning here is specified to be painted on a black background, though photos do not confirm such a detail."

Plans for the CS-30 are on the following pages.

Diag
49.

Diagram of 36 Ft. 40 Ton Flat Car. Class C.S. 30.

Office of Supt. M.P. S.P.Co. Sacramento May 25, 1903.

NOTE: -When car is loaded to capacity with lumber (at 40 lbs per cu ft) the Center of Gravity is at A, 6'-3" from top of rail.

- Weight of Car _____ 24000 lbs.
- Capacity _____ 80000 lbs.
- Length over end sills _____ 36'-7 $\frac{1}{2}$ "
- Width over side sills _____ 8'-9"
- Width of floor _____ 9'-0"
- Width over stake pockets _____ 9'-7 $\frac{1}{2}$ "
- Height top of rail to top of floor _____ 50"
- Floor area _____ 329 sq. ft.
- Stake pockets _____ 38 x 3 $\frac{1}{2}$

40 Ton Rigid Truck.

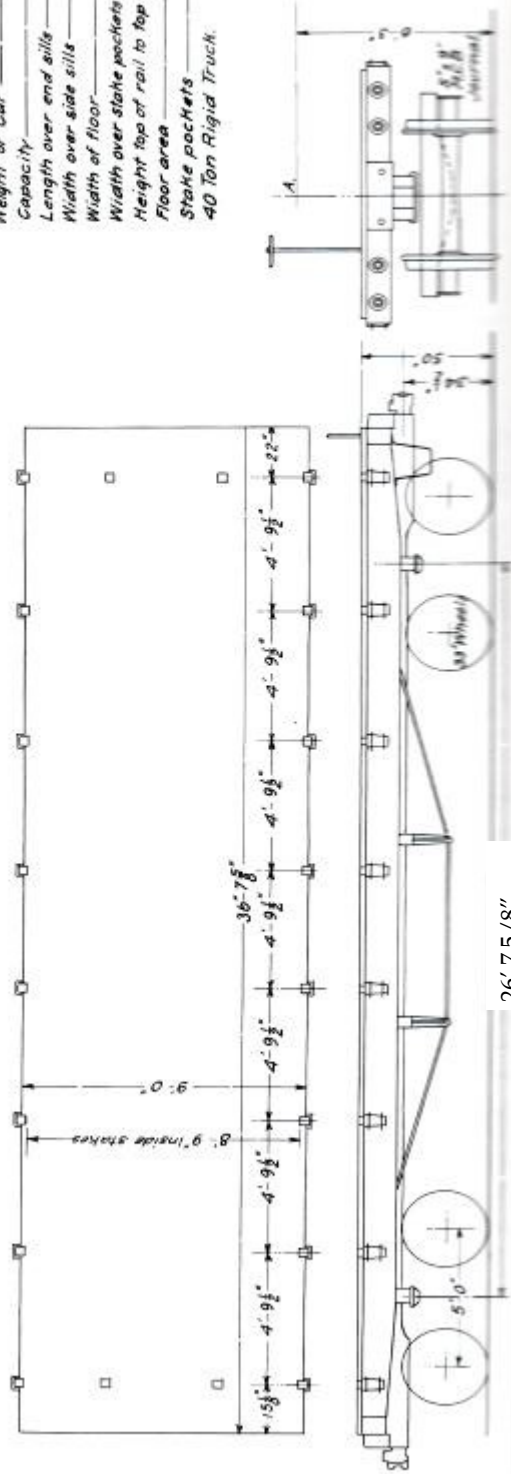

(Drawing courtesy of Arnold Menke collection. Image scanned from SP Freight Cars, Vol. 3, pg. 398, courtesy of Anthony Thompson)

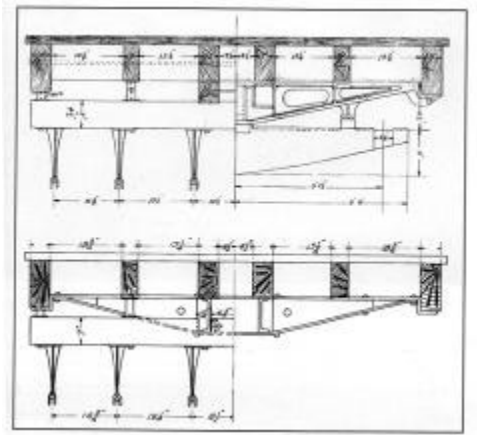
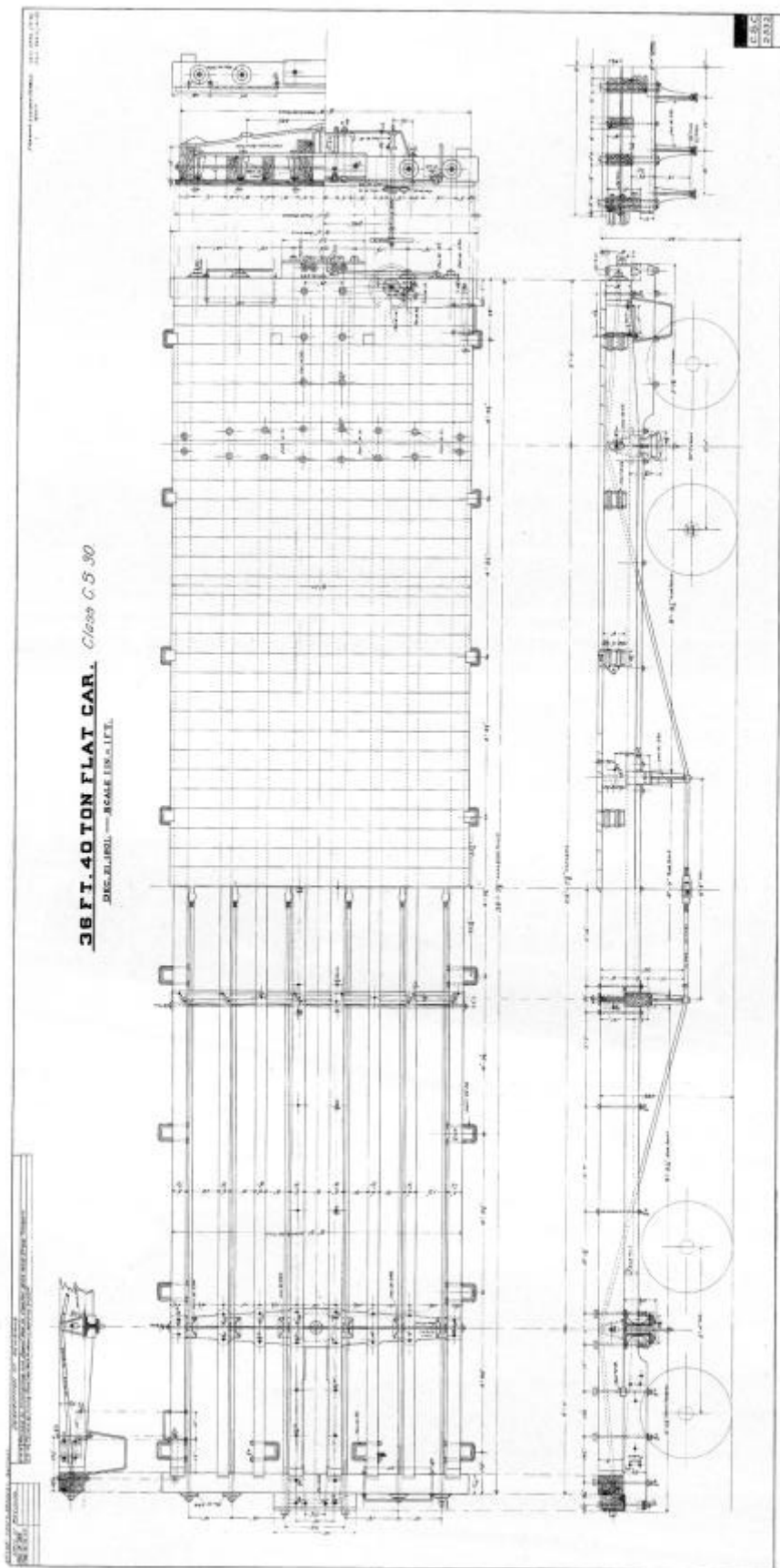

The wood-underframe flat cars of CS-22 and CS-30 were reinforced after 1908 with new steel body bolsters and steel channel draft sills between bolsters. This drawing for CS-22 shows cross sections for the original (above) and the modified (below) arrangements. Reinforcement of CS-30 was quite similar. Details taken from SP drawings CSC 1863 and 7282.

(Drawing courtesy of California State Railroad Museum. Image scanned from SP Freight Cars, Vol. 3, pg. 171, and rewritten text courtesy of Anthony Thompson)

(Drawing courtesy of California State Railroad Museum. Image scanned from SP Freight Cars, Vol. 3, pg. 168, courtesy of Anthony Thompson)

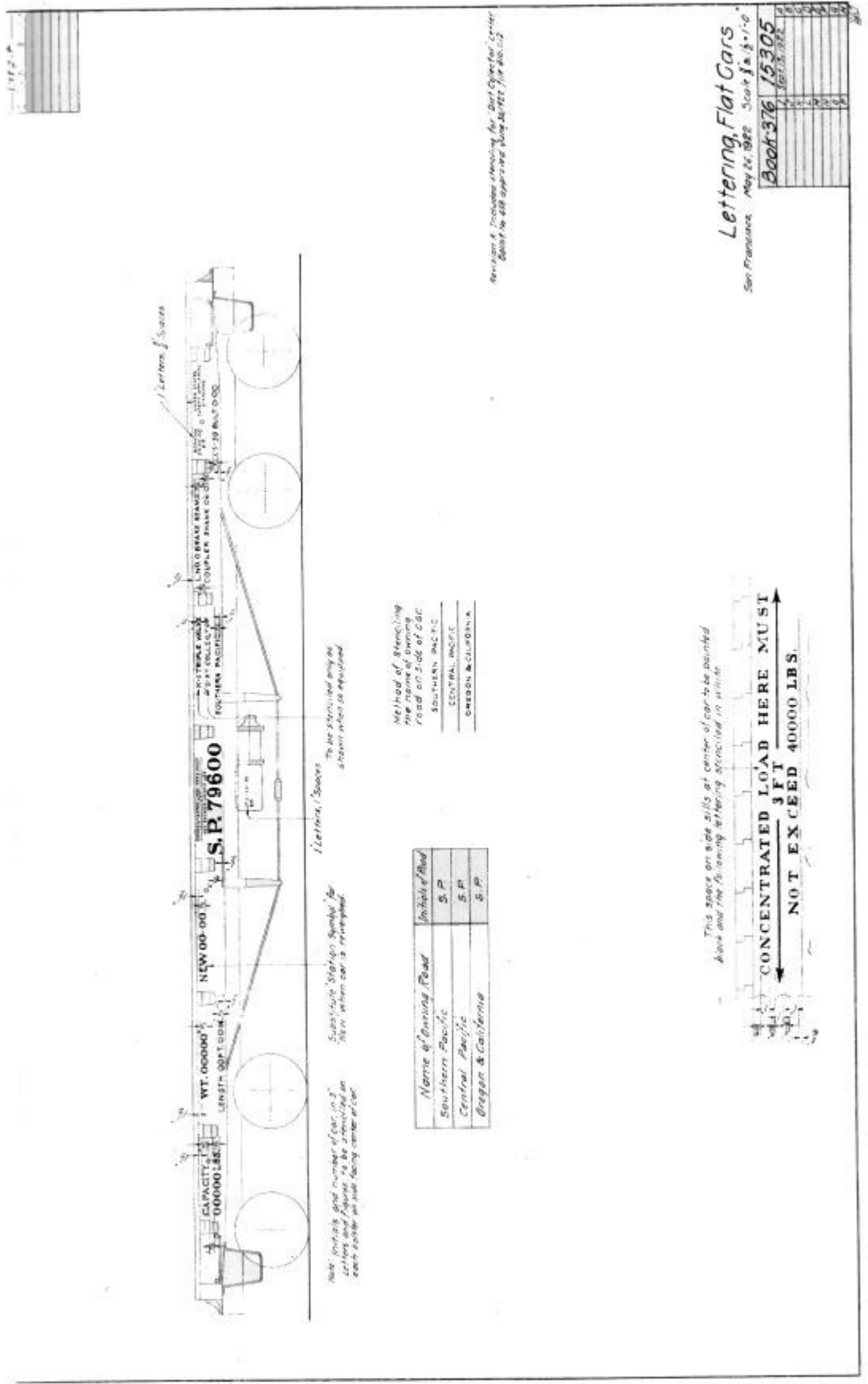

WT. 00000
LENGTH 00 FT 00 IN
NEW 00-00
S. P. 79600
EASTERN PACIFIC
SOUTHERN PACIFIC
CENTRAL PACIFIC
OREGON & CALIFORNIA

Letters, / Sizes
Letters, / Sizes
Letters, / Sizes

Must indicate and number of car, in 2 letters and figures to be attached on each side at side facing center of car.
Substitute Station Symbols for 'NEW' when car is reworked.
To be furnished only as shown when so specified.

Method of numbering	Name of owning Road	Initial of Road
SOUTHERN PACIFIC	Southern Pacific	S. P.
CENTRAL PACIFIC	Central Pacific	S. P.
OREGON & CALIFORNIA	Oregon & California	S. P.

Revision 4. Includes drawing for Bolt Operator Center. Given by SPB approval Aug. 20, 1922. No. 20112.

This space on side sills at center of car to be painted blue and the following lettering attached in white



Lettering, Flat Cars
San Francisco May 25, 1922 Scale 3/8" = 1'-0"
Book-376 15305
NOT TO SCALE

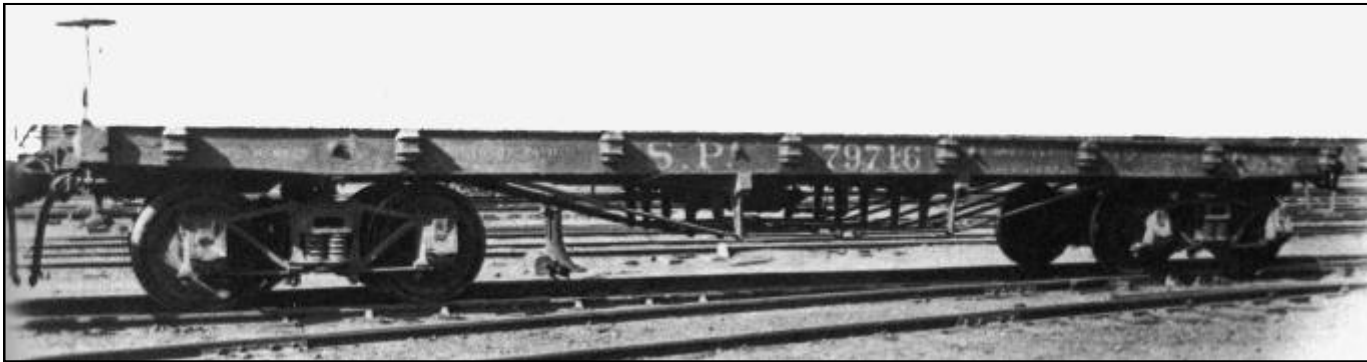

One thousand cars of the CS-30 design were built, though the steel underframe was about to become standard. This photo was taken of a car in service about 1913. (permission granted Shasta Division Archives)

(Text rewritten and both images were scanned from SP Freight Cars, Vol. 3, pg. 167, courtesy of Anthony Thompson)



A builder photo of CS-30 car no. 79663. Its completion date was May 28, 1902. The CS-30 cars differed from CS-22 in returning to 36-foot length, but supported 40 tons on six truss rods.

(permission granted by Cyril Durrenberger, AC&F photo)



Jim Long photos, August 18 meet, V&T RR.



I'd like to thank the many people and organizations that contributed or gave permission to use material for this issue. It's not just the sharing material, but the time it takes communicating with me.

Martin Brechbeil, Barb Keller, Nevin Wilson, Jim Petro, Jim Long, Chris Butler, Duane Richardson, Anthony Thompson, Arnold Menke, Cyril Durrenberger, Mid-Eastern Region/NMRA, NMRA Lone Star Region—Div. 3, Shasta Division Archives, and the California State Railroad Museum.

Thanks!

Gary Ray—Editor